



Deze download wordt u gratis aangeboden door Pick-upnaalden.nl

Web : www.pickupnaalden.com
Email : info@pick-upnaalden.nl
Facebook : www.facebook.com/pickupnaalden
Twitter : twitter.com/Pickupnaalden
Google+ : https://plus.google.com/+FCaris_pickupnaalden

ONKYO® SERVICE MANUAL

QUARTZ LOCKED DIRECT DRIVE FULLY AUTOMATIC TURNTABLE MODEL CP-1500F



UD, UD Ⓜ	120V AC, 60Hz
UG, UGV	220V AC, 50Hz
U, U	110/120/220/240V AC, 50/60Hz
UQA, UQB	240V AC, 50Hz

SAFETY-RELATED COMPONENT WARNING!!

COMPONENTS IDENTIFIED BY MARK \triangle ON THE SCHEMATIC DIAGRAM AND IN THE PARTS LIST ARE CRITICAL FOR RISK OF FIRE AND ELECTRIC SHOCK. REPLACE THESE COMPONENTS WITH ONKYO PARTS WHOSE PARTS NUMBERS APPEAR AS SHOWN IN THIS MANUAL.

MAKE LEAKAGE-CURRENT OR RESISTANCE MEASUREMENTS TO DETERMINE THAT EXPOSED PARTS ARE ACCEPTABLY INSULATED FROM THE SUPPLY CIRCUIT BEFORE RETURNING THE APPLIANCE TO THE CUSTOMER.

SPECIFICATIONS

Type:	Quartz locked direct drive fully automatic turntable with auto lead-in and return, reject, repeat, cue and search button functions, two-motor micro-computer design
Turntable Platter:	310 mm (12-1/4") aluminum die-cast.
Motor:	Quartz locked direct drive brushless DC motor
Speeds:	33-1/3, 45 rpm
Wow & Flutter:	less than 0.025% (WRMS)
Signal-to-Noise Ratio:	better than 75dB (DIN B)
Tonearm:	Statically balanced straight type
Effective Arm Length:	224 mm (8-7/8")
Overhang:	13 mm (1/2")
Offset Angle:	21 degrees
Maximum Tracking Error:	+3 degrees, -1.5 degrees
Suitable Cartridge Weight:	Min. 5, Max. 9 grams
Tracking Force:	0 - 3.0 grams
Other Features:	Tracking force direct readout scale Removable headshell Anti-skating device

ONKYO®
AUDIO COMPONENTS

Dimensions (W x D x H)	418 x 376 x 132 mm (16-1/2" x 14-13/16" x 5-1/5")
Weight:	6.0 kg (13.2 lbs.)
Accessories:	Headshell, counterweight, overhang gauge, adapter, instruction manual

Optional Recommended Headshell: SH-21E

Specifications are subject to change for further product improvements.

SERVICE PROCEDURES

Insulation resistance measurement

Connect the insulating-resistance tester between the plug of power supply cord and chassis.

Specifications; D model	500 V 3.3±0.33 MΩ
G/W models	500 V more than 10 MΩ

ADJUSTMENT PROCEDURES

1. Return sensitivity adjustment (fig. 1)

Turn the unit upside-down and, with the DD motor and arm motor connector removed, connect a DC voltmeter between TP and GND. Move the arm to the inside of the platter, put the return sensor in the release position and shut out extraneous light. Starting with the semi-fixed resistor R703 set all the way to the left, begin to rotate the resistor clockwise to the point where the voltage between TP and GND rises 2mV above low (a few hundred mV).

2. Platter height adjustment (fig. 2)

Return the unit to the upright position and rotate the float base height adjustment screw. Adjust so that the platter height is 13mm ± 2mm above the cabinet.

3. Stylus height adjustment

Set the tonearm in the up position and adjust the lifter plate screw so the height of the stylus tip is 8mm ± 1mm above the platter mat.

Note 1: The height should be 11mm ± 2mm measured from the surface of the platter.

Note 2: Rotate the lifter plate screw counterclockwise to lower the stylus height and clockwise to raise the stylus height.

4. Lead-in count adjustment (Tracking force: 2 grams Anti-skating force: 2 grams Speed: 45 rpm)

Using test record ONK-1000, adjust so the lead-in count is 10-20 counts for both 30cm and 17cm records. Adjust using the PU pulley shutter and NCDG-1731 printed circuit board jumper lead.

The count changes in the following manner as the jumper leads are cut:

Jumper lead A	3 count changes
Jumper lead B	6 count changes
Jumper lead C	12 count changes
Jumper lead ±	cut: - . connect: +

5. Return count adjustment (Speed: 45 rpm)

Using test record ONK-1000, adjust so the 3mm pitch return count is 24-26 counts. Adjust using the PU pulley eccentricity pin. Confirm that the tonearm does not return until 22 counts at a pitch of 1mm.

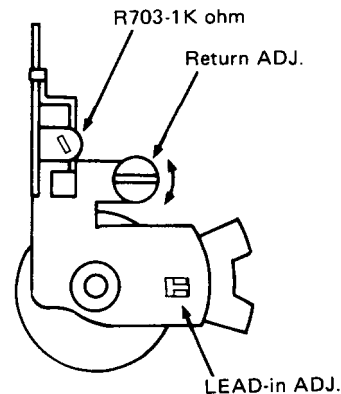

fig. 1

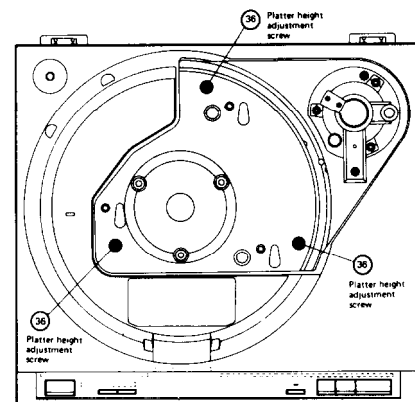
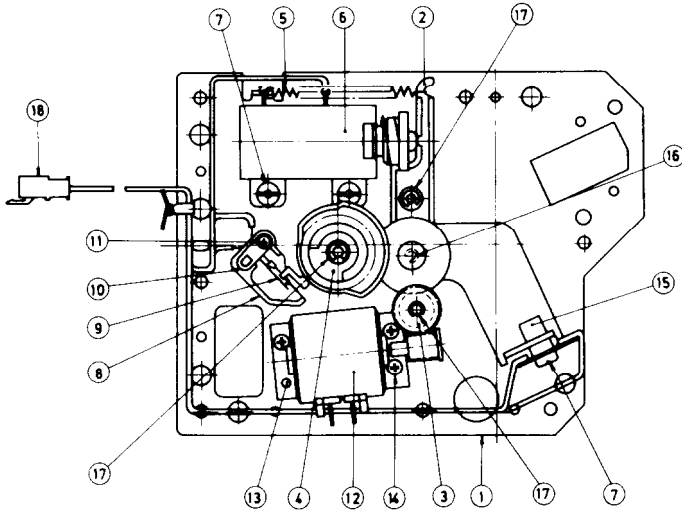

fig. 2

MECHANISM COMPONENT LOCATION



REF. NO.	PARTS NO.	DESCRIPTION
1	24506644	Chassis
2	24504310	Lever
3	24503097	Wheel
4	24503098	Cam wheel
5	24503100	Tension spring
6	24506474	Solenoid
7	24506437	Screw
8	24506463	Cover
9	24503102	Switch
10	24509234	Spacer
11	82112024	2P-24FN, Pan head screw
12	24502125B	Motor ass'y
13	24506464	Rubber plate
14	82142306	2.3P + 6FN (BC), Pan head screw
15	24506596	Photo diode/transistor ass'y
16	893030	E-3, Circlip
17	893020	E-2, Circlip
18	2000241	NSAS-8P179, Socket
19		Belt
20		Label
21	24506658	Screw
22	24506659	Toothed washer
23	24506461	Rubber ring

MICROCOMPUTER

TMP4315BP (1033)

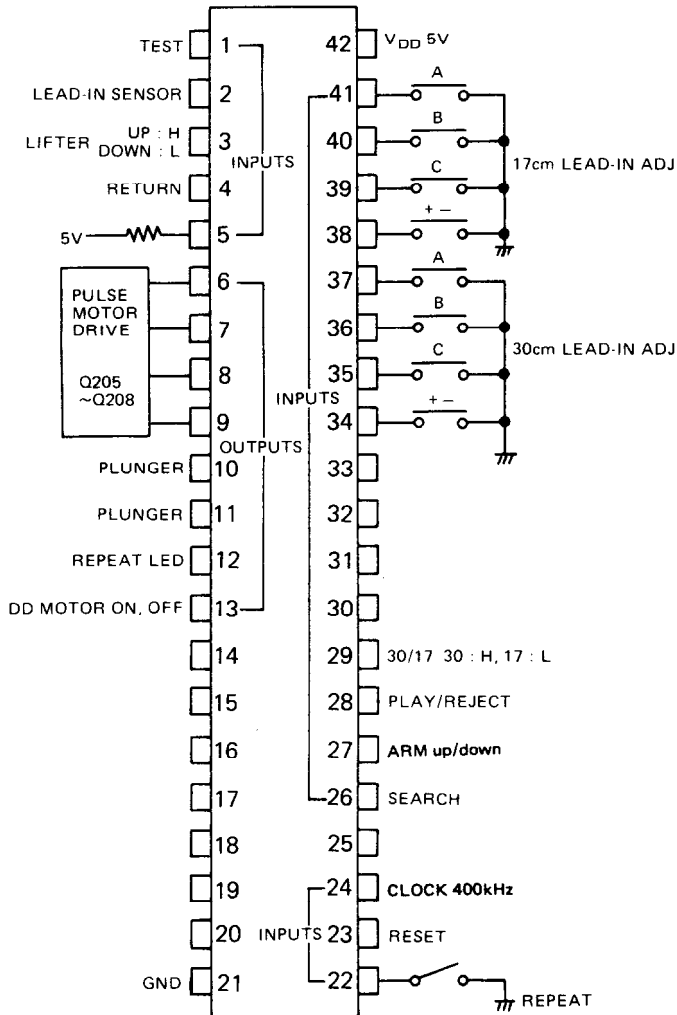

COMPONENT LOCATION PART LIST

REF.NO.	PART NO.	DESCRIPTION			
1	28110500	CABINET (D)			
	28110501-1	CABINET (G/U/UQ)			
4	28110303A	FLOATING BASE AS (D)			
	28110290	FLOATING BASE AS (G/U/UQ)			
9	24509320A	DUST COVER AS			
11	28180080	HINGE AS			
13	28153082	BOTTOM BOARD (D)			
	28153076A	BOTTOM BOARD (G/U/UQ)			
17	24502159A	PLATTER			
19	27140866	BRACKET (B)			
23	27141348A	BRACKET (RI)			
24	27141349	BRACKET (G)			
25	27140856	BRACKET (A)			
26	28140209	CUSHION (PT)			
27	28140496A	CUSHION			
29	28140507	CUSHION			
31	24509325	INSULATOR AS (H)			
32	24509326	INSULATOR AS (I)			
33	24509314	INSULATOR AS (Y)			
34	24509327	INSULATOR AS (J)			
35	28323778B	KNOB AS (R)			
36	28321549-1	KNOB (S)			
37	28321330-1	KNOB (L)			
38	27260119B	SHAFT (POW)			
39	27140794A	BRACKET (POW)			
40	27260120A	SHAFT (S)			
42	8930301S	E WASHER ES-3S			
43	27267335	GUIDE (L)			
44	28191525	CLEAR PLATE (D)			
	28191525-1	CLEAR PLATE (G/U/UQ)			
45	27262513	PLATE			
46	28198596	FACET			
47	28133078	BACK PLATE (A)			
48	28133079	BACK PLATE (B)			
49	28321163-1	KNOB AS (I.F.C.)			
50	28400012B	I.F.C. CAM			
51	27180175-1	SPRING (I.F.C.)			
52	27267271	GUIDE (I.F.C.)			
53	870071	WAVE WASHER WW-6			
54	24506645A	ARM REST AS			
55	24506648	PLATE (LIFTER)			
56	27260121A	SHAFT (S)			
57	27180156	SPRING			
58	27180140-1	SPRING			
59	8930301S	E WASHER ES-3S			
60	87644012	WASHER W4×12			
61	831430120	TAP-TIGHT SCREW 3TTW+12P(BC)			
62	831430100	TAP-TIGHT SCREW 3TTW+10P(BC)			
63	833440120	TAP-TIGHT SCREW 4TTP+12P(BC)			
64	833440200	TAP-TIGHT SCREW 4TTP+20P(BC)			
66	834430108	TAP-TIGHT SCREW 3TTS+10B(BC)			
68	801275	SPECIAL P-TIGHT SCREW			
70	87644012	WASHER W4×12F(BC)			
71	8761401816	WASHER W4×18F			
72	27270115	SPACER			
73	87313006	TOOTH LOCK WASHER M3-B			
74	87643010	WASHER W4×10F(BC)			
75	27265083	RING 4×5.3×14L			
76	870060	FIBER WASHER W3×15 BLACK			
P1	25045262	HSJ0780-01-010 ST JACK (D)			
M1	24502155B	787V MOTOR AS			
			PT1	▲ 230734A	NPT-816D (D)
				▲ 230795	NPT-816G (G)
				▲ 230735	NPT-816ADGQ (U)
				▲ 230736	NPT-816Q (UQ)
			P31	24506642B	FULL-AUTO MECHANISM AS N-35
			P32	24501457A	TONE ARM
				24501325	HEAD SHELL
				24501460	COUNTER WEIGHT
				24501330	COMBINING ACCESSORY
				242960	OC-61VE CARTRIDGE AS (G/U/UQ)
				242959	DN-61STE STYLUS (G/U/UQ)
		SW1	▲ 25035385	NPS-111-L349P (D)	
			▲ 25035386	NPS-111-L350P (G/U/UQ)	
		SW2	▲ 25065168	HXW0131-01-060 VOLTAGE SELECTOR (U)	
		U1	1H089531-2	NADG-1731-2	
		U2	▲ 1H089584-2	NAPS-1684-2 (D)	
			▲ 1H089584-2A	NAPS-1684-2A (G/U)	
			▲ 1H089584-2B	NAPS-1684-2B (UQA)	
			▲ 1H089584-2C	NAPS-1684-2C (UQB)	
		U3	1H089532-2	NASW-1732-2	
		U4	1H089533-2	NALED-1733-2	
		U5	1H089534-2	NASW-1734-2	
		U6	1H089535-2	NALED-1735-2	
		U7	1H089510-2	NAPI-1010-2 (D)	
			1H089510-2A	NAPI-1010-2A (G/U/UQ)	
		U8	1H089550-7	NARET-2350-7	

NOTE: (D) : Only 120V model
(G) : Only 220V model
(U) : Only Universal model
(Q) : Only 240V model
(QA) : Only Australia model
(QB) : Only U.K. model

NOTE : THE COMPONENTS IDENTIFIED BY MARK ▲
ARE CRITICAL FOR LISK OF FIRE AND
ELECTRIC SHOCK. REPLACE ONLY WITH
PARTS NUMBER SPECIFIED.

CP-1500F CP-1500F

COMPONENT LOCATION

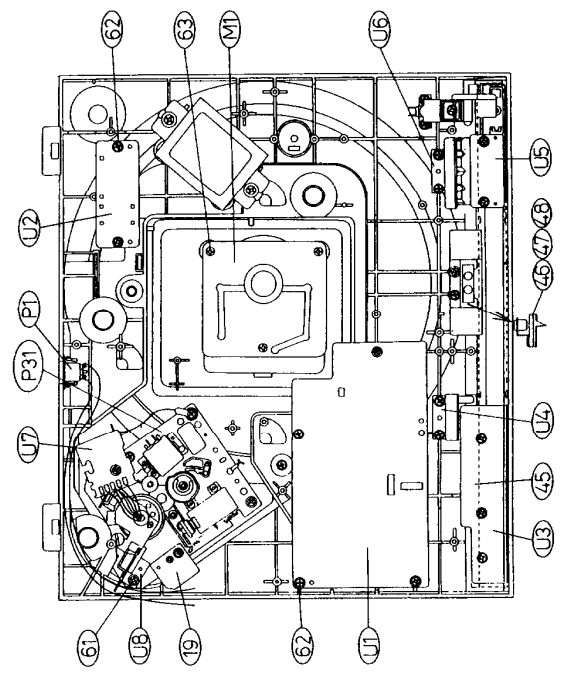
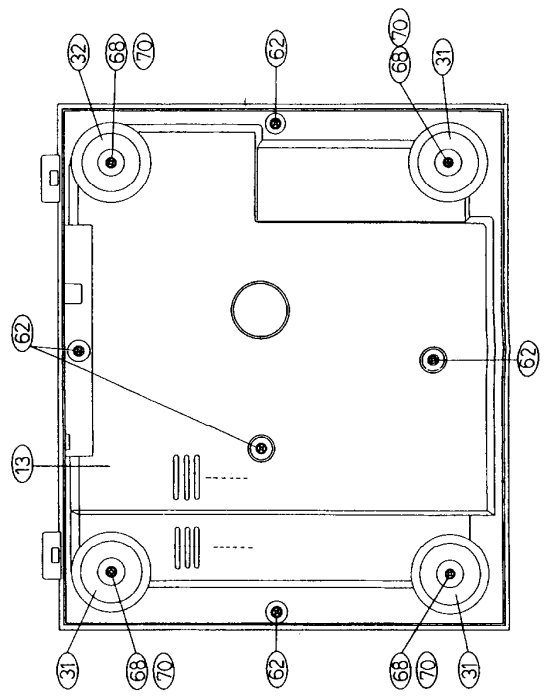
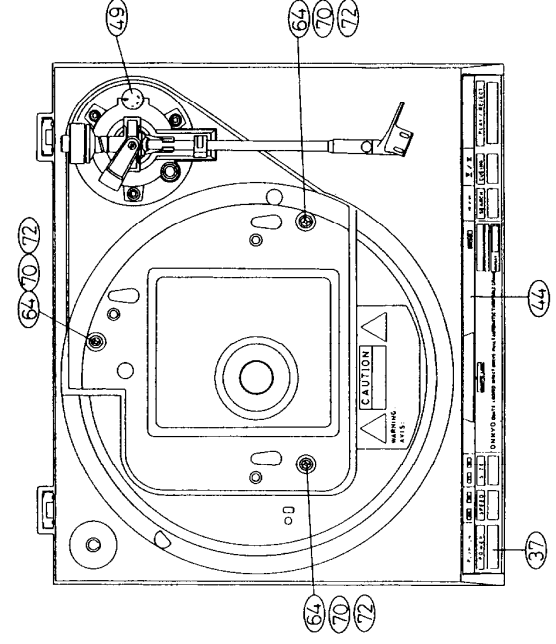
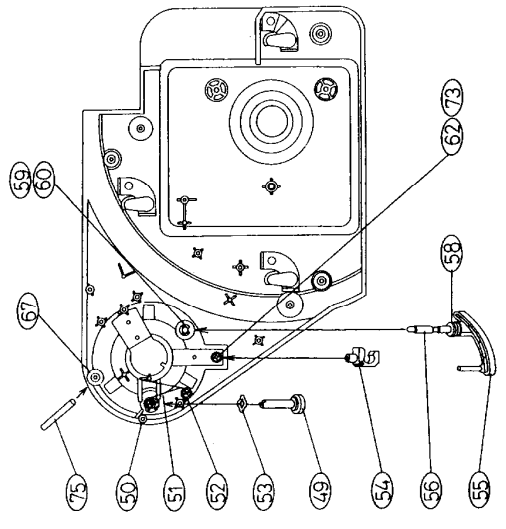
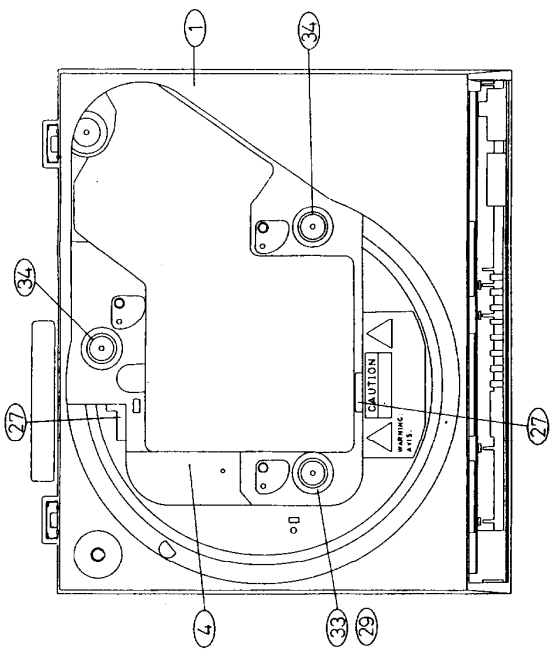
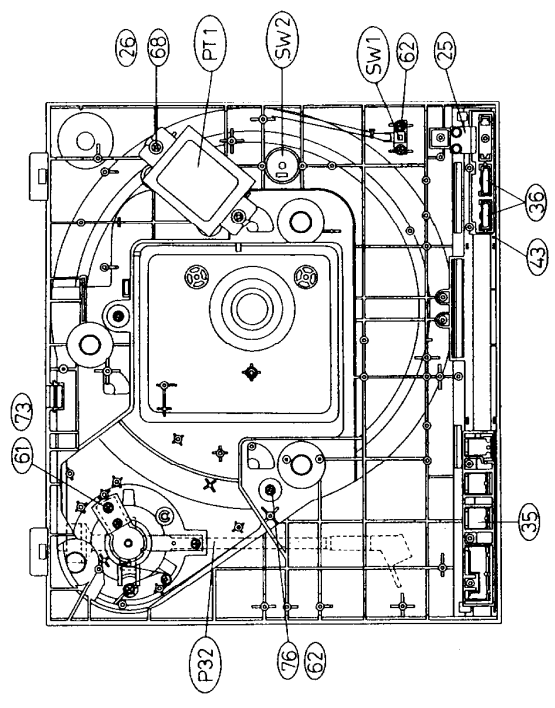

PRINTED CIRCUIT BOARD PART LIST

NADG-1731-2

CIRCUIT NO.	PART NO.	DESCRIPTION
Q201	222925	TMP-4315BP (1033)
	ic	
Q203	2211255 or 2210746	2SC1815-GR or 2SC945-AP
Q204	2211706	2SD655-F
Q205	2211255 or 2210746	2SC1815-GR or 2SC945-AP
Q206-Q209	2211544	2SC1959-Y
Q210	2211255 or 2210746	2SC1815-GR or 2SC945-AP
Q211	2211644	2SA965-Y
Q212, Q213	2211255 or 2210746	2SC1815-GR or 2SC945-AP
Q219	2211253, 2211254, 2211255, 2210746, 2210747 or 2210748	2SC1815-O, 2SC1815-Y, 2SC1815-GR, 2SC945-AP, 2SC945-A-Q or 2SC945-A-K
Q301, Q302	2211255	2SC1815-GR
Q901	2201074	2SD880-Y
Q903, Q904	2201074	2SD880-Y
	Diodes	
D201, D202	223145, 223150, 223105 or 223133	1S2076TD, US1040, 1S1555 or DS-442X
D205	223103 or 223132	1N60 or 1K60
D206-D209	223145, 223150, 223105 or 223133	1S2076TD, US1040, 1S1555 or DS-442X
D901	223890 or 223869	W01RL or W-01
D903	224151803, 2241193 or 224452002	05AZ18Z, GZA-18Z or MTZ-20B
D904	223145, 223150, 223105 or 223133	1S2076TD, US1040, 1S1555 or DS-442X
D905	2241132 or 224151302	GZA-13Y or 05AZ13Y
D906	2240951 or 224150561	GZA-5.6X or 05AZ5.6X
D907	2241132 or 224151302	GZA-13Y or 05AZ13Y
D908	223848	GP-08B
	Coil	
L201	232108	NMIF-6042
	Capacitors	
C202	354780109	1 μ F50V, ELECT.
C301	354734709	47 μ F10V, ELECT.
C302	354733309	33 μ F10V, ELECT.
C903, C904	352761029S	1000 μ F35V, ELECT.
C906-C908	352764709	47 μ F35V, ELECT.
C910	354744709	47 μ F16V, ELECT.
C911	354764709	47 μ F35V, ELECT.
	Resistors	
R201-R204	49121472404	4.7k Ω \times 4, 1/8W
R205-R209	49121332405	3.3k Ω \times 5, 1/8W
R210-R217	49121223408	22k Ω \times 8, 1/8W
R903, R904	441722204F	RS2WBJ, 22 Ω
R905	441721804F	RS2WBJ, 18 Ω
R907	441626804F	RS2WBJ, 68 Ω
	Socket, Plugs	
	2000239	NSAS-5P177
	2000236	NSAS-3P174
	2000237	NSAS-3P175
	25055089	NPLG-3P73
	25055091	NPLG-5P75

CIRCUIT NO.	PART NO.	DESCRIPTION
	25055093	NPLG-7P77
	25055094	NPLG-8P78
	Lamp	
	210175	14v60mA
	Miscellaneous	
	27160029	RAD07, RADIATOR
	82143006	3P + 6FN(BC), SCREW
	27140790	BRACKET
	79136	S21E12

NAPS-1684-2

CIRCUIT NO.	PART NO.	DESCRIPTION
C911	3500065A	0.01 μ F, AC400V, IS.
	Miscellaneous	
	253112A	AS-UC-4, POWER SUPPLY CORD
	270280	SR-4K-4, STRAINRELEIEF
	27140393	BRACKET(AC)

NASW-1732-2

CIRCUIT NO.	PART NO.	DESCRIPTION
	25035291	NPS-111-S257, PUSH SWITCH
	2000240	NSAS-7P178, SOCKET

NALED-1733-2

CIRCUIT NO.	PART NO.	DESCRIPTION
	225142	SEL2913K, LED
	27250062	LAMP CASE
	27140795	BRACKET(U)
	833430080	3TTP+8P, SCREW

NASW-1734-2

CIRCUIT NO.	PART NO.	DESCRIPTION
	25035399	NPS-122-L364, PUSH SWITCH
	2000249	NSAS-5P187, SOCKET

NALED-1735-2

CIRCUIT NO.	PART NO.	DESCRIPTION
	LED	
D601	225142	SEL2913K
D602	225137CG or 225137DG	SEL2413E-CG or SEL2314E-DG
D603	225142	SEL2913K
D604	225137CG or 225137DG	SEL2413E-CG or SEL2314E-DG
	Miscellaneous	
	27250061	LAMP CASE
	27140795	BRACKET(U)
	833430080	3TTP+8P(BC), SCREW

NAPI-1010-2

CIRCUIT NO.	PART NO.	DESCRIPTION
P802	24505155	PU CORD

NAPI-1010-2A

CIRCUIT NO.	PART NO.	DESCRIPTION
P802	24505158A	PU CORD

NARET-2350-7

CIRCUIT NO.	PART NO.	DESCRIPTION
	Transistor	
Q701	2211255	2SC1815GR
	LED	
D701	225053 or 225054	SEL1110R-B or SEL1110R-C
	Diode	
D702	225226	HPL-3F
	Resistor	
R703	5215051	N08HR1kBF
	Miscellaneous	
	2000238	NSAS-3P176, SOCKET
	27140411A	BRACKET(L)
	834430068	3TTS+6B(BC), SCREW

PACKING VIEW

4 TTP+25P 801434
W4×12F(BC) 87644012 Tapping screw
Spacer (27270115)

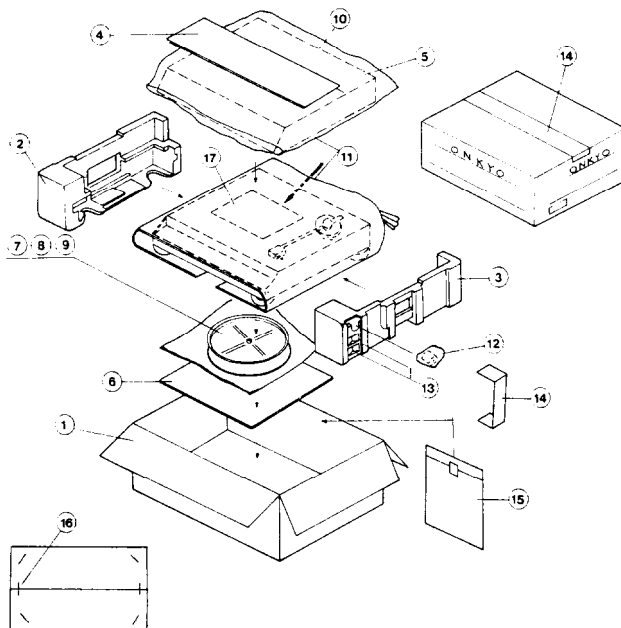
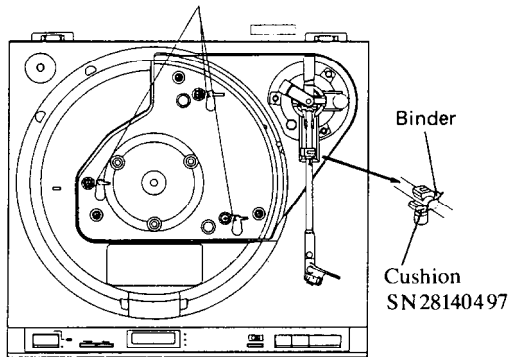

REF.NO	PART NO.	DESCRIPTION
1	29051972	Master carton box
2	29090916A	Pad(L)
3	29090917A	Pad(R)
4	29090918A	Pad Sheet(Up)
5	29095366	Pad Sheet(Tone arm)
6	29095286	Pad sheet(Bottom)
7	24502159A	Turntable platter
8	24509328	T.T Mat (Only 120V model)
	24509286A	T.T Mat (Only 220V model)
9	29100046	Poly-vinyl bag
10	24509320A	Dust cover
11	290008-1	Protection sheet
12	24501460	Counter weight
	29100072	80×150 poly bag
13	28180080	Hinge
	29095363	70×140 ×0.15t sheet
14	29110051	P.P Tape(W60×220mm)
	260012	P.P Tape(W50×1000mm)
15		Accessory bag complete
	120V model	
	29341450	Instruction manual
	24501330	Cartiridge attachment parts ass'y
	24509197	Overhang gauge
	29365019	Warranty card(Only USA model)
	29358002G	Service station list(Only USA model)
	29100006A	250×350 Poly bag
	292049A	45 Adaptor
	220V model	
	29341451	Instruction manual
	29365020A	Warranty card(Only West Germany model)
	29100094	Poly bag
	29100006A	250×350 Poly bag
	292049A	45 Adaptor
	Universal model	
	29341451	Instruction manual
	25055040	CVK-2, Conversion plug
	29100006A	250×350 Poly bag
	29365022	Warranty card (Only U.K.model)
	292049A	45 Adaptor
16	282301	Sealing hook
17	29355101B	Caution label

ONKYO CORPORATION

International Division: Onarimon Yuusen Bldg., 23-5, Nishi-Shimbashi 3-chome, Minato-ku, TOKYO 105, JAPAN Tel: 03-432-6987 Fax: 03-436-6979

ONKYO DEUTSCHLAND GMBH, ELECTRONICS

8034 München-Germering, Industriestrasse 18 West Germany. Fax: 49-89-849-3226 Telefon: (089)-84-3071

ONKYO Europe GmbH

Hellersbergstrasse 4. 4040 Neuss WEST GERMANY
Tel: 02101 12 00 75 Fax: 02101 10 33 06

ONKYO U.S.A. CORPORATION

200 Williams Drive, Ramsey, N.J. 07446 Telex: 25-710-988-1033 Tel. 201-825-7950