



Deze download wordt u gratis aangeboden door Pick-upnaalden.nl

Web : www.pickupnaalden.com
Email : info@pick-upnaalden.nl
Facebook : www.facebook.com/pickupnaalden
Twitter : twitter.com/Pickupnaalden
Google+ : https://plus.google.com/+FCaris_pickupnaalden

ONKYO® SERVICE MANUAL
QUARTZ LOCKED DIRECT DRIVE
FULLY AUTOMATIC TURNTABLE
Model CP-1280F



TABLE OF CONTENTS

Item	Page
Specifications	2
Features	2
Circuit description	3
Service procedures and alignment	6
Exploded view	9
Printed circuit board view from bottom side	11
Printed circuit board-parts list	12
Schematic diagram	13
Parts list	15
Packing procedures	16



SPECIFICATIONS

Type:	Direct drive fully automatic turntable with auto lead-in and return; reject and repeat function also included; two motor design with cueing lever.
Turntable Platter:	33 cm (13") aluminum die-cast, 2.3 kg (5 lbs.) (with mat)
Motor:	Quartz lock synthesized DD motor
Speeds:	33-1/3, 45 rpm, adjustable $\pm 6\%$
Wow & Flutter:	less than 0.025% (WRMS)
Signal-to-Noise Ratio:	better than 75 dB (DIN B)
Tonearm:	Statically balanced straight type, carbon fiber/pipe construction.
Effective Arm Length:	237 mm (9 3/8")
Overhang:	16 mm (5/8")
Offset Angle:	21 degrees

Maximum Tracking Error:	+2.5 degrees, -0.8 degrees
Suitable Cartridge Weight:	4 - 11 grams
Tracking Force:	0-2.0 grams
Other Devices:	Tracking force direct readout scale Removable headshell Dia-type anti-skating control
Power supply:	AC 120V/220V 50/60Hz (or 120V 60Hz, or 240V 50Hz)
Power consumption:	7 watts
Dimensions (WxDxH):	480 x 408 x 162 mm (18 7/8" x 16 1/16" x 6 3/8")
Weight:	11.5 kg (25.5 lbs.)
Accessories:	Headshell, counterweight, overhang gauge, 45 rpm adapter, instruction manual.

Specifications are subject to change for further product improvements.

FEATURES

Improved moment-to-moment response thanks to low tonearm mass

Ideally, the tracking force of a statically balanced tonearm, being determined by the respective weights in front and behind the pivot point, has nothing to do with the effective mass of the tonearm itself. A counterweight of sufficient weight is simply adjusted to provide the appropriate amount of tracking force. This tracking force remains constant only when we are dealing with a perfectly flat and perfectly round disc. However, all records have some amount of warp and eccentricity which upset this ideal condition. During one revolution, the tonearm moves sideways (caused by eccentricity) and vertically (caused by warp) to trace the record grooves. Because the greater the effective mass of the tonearm, the greater its inertia is (see diagram), the result is poor tracking performance and consequent poor moment-to-moment response.

To minimize effective mass, this tonearm employs:

(1) straight-line design, the shortest distance between pivot and stylus tip (2) carbon fiber, with a specific gravity less than half that of aluminum (3) a slimmer pipe thanks to the higher rigidity of the straight-line/carbon fiber construction (4) smallest possible shell within performance requirements with miniature ADD-type connector. All this means the effective mass is approximately 15 grams (with a 6 gram cartridge), roughly half that of Onkyo's standard S-type tonearms. At a 2 gram tracking force setting, the resulting difference in sensitivity can be seen in the following example as the stylus moves over a typical record:

30 gram effective mass at stylus tip	2.5 - 1.8 g
15 gram effective mass at stylus tip	2.2 - 1.9 g

As the effective mass decreases, the variations in tracking force dramatically decrease as well and the trackability of the tonearm increases by the same margin.

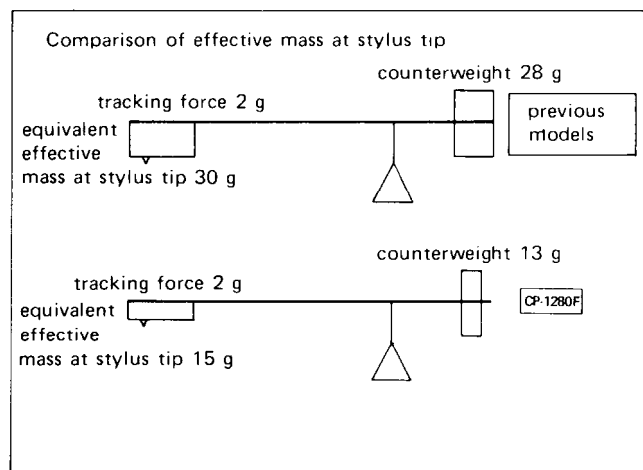

High torque quartz locked direct drive motor guarantees superior rotational stability and accuracy.

The 20-pole 30-slot high torque motor with its quartz locking system assures that excellent rotational stability is maintained even during abrupt changes in the load. The quartz lock system is a frequency generator (FG) connected to the shaft to detect and correct any variations in the turntable speed. A reference frequency is taken from a 5.52960 MHz quartz oscillator, divided down and compared with the signal from the FG. Any variations in speed, no matter how small, are immediately detected and corrected by this servo circuit.

The reference quartz oscillator uses the same type of quartz control as that found in chronometers. It virtually eliminates drift caused by time and temperature and overcomes variations in load while locking the turntable speed to exactly the correct value. To improve the reliability and precision of this complex circuitry, IC's have been used throughout, the frequency generator is completely integrated to totally cancel any speed fluctuations of the platter, and an extremely stable quartz PLL circuit is employed.

CIRCUIT DESCRIPTION

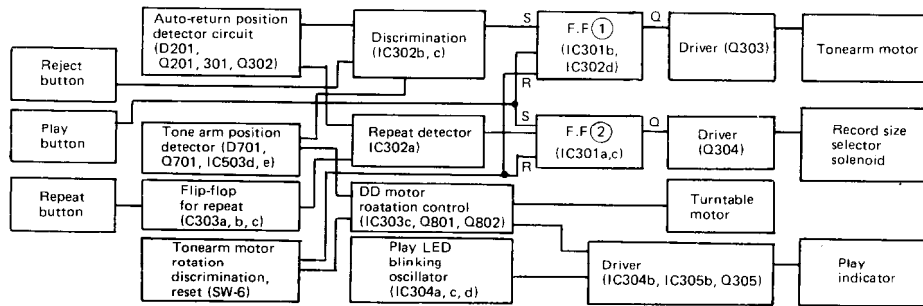

BLOCK DIAGRAM OF THE SYSTEM CONTROL CIRCUIT

1. Operation when power switch (SW1) is turned on

- 1) When the power switch (SW1) is turned on, both flip-flops are reset by C304, 305, 307, 308, 316, and 317, and are maintained in the following stabilized states:

IC301 #6 (L)

IC301 #8 (L)

Q303 and Q304 will thus be turned off, thereby preventing the tonearm drive motor and record size selector solenoid from being switched on. Furthermore, with

IC303 #6 (L)

the REPEAT LED will also be kept off.

- 2) However, because of IC303 #8 (L) status, Q801 and Q802 will also be kept off.
- 3) Hence, no voltage will be applied to the emitter of Q09, and the turntable motor will remain stationary.

2. Auto Start Operation

When PLAY button (SW7) is pressed

- 1) IC301 #3 and #9 are switched from (H) to (L), resulting in FF(1) and FF(2) being inverted, and Q303 and Q304 being turned on. The tonearm drive motor and size selector solenoid will thus be activated.
- 2) This results in the GEAR switch (SW6) being turned on, and IC303 #9 being switched from (H) to (L). Q305 is then turned on via IC304b and IC305b, thereby lighting up the PLAY LED (red).
- 3) On the other hand, a signal from the PLAY LED blinking oscillator circuit is applied to IC304 #6, resulting in #4 being switched to (H) while #6 is (L), irrespective of the (L)/(H) status of #5. Q305 is thus turned off, and the LED extinguished.
- 4) The LED consequently blinks on and off in accordance to the oscillator circuit cycle time.
- 5) In addition, at the same time that the GEAR switch (SW6) is turned on, IC303 #9 is switched to (L), resulting in #8 being switched to (H), and Q801 and Q802 being turned on. A voltage is then applied to the emitter of Q09.
- 6) The turntable motor drive circuit is thus activated, thereby starting up the turntable.
- 7) And once the large gear starts to turn, the mechanical drive is activated, resulting in the automatic lead-in of the tonearm.
- 8) When the large gear then stops turning, negative pulses are generated by IC301 #2 and IC302 #13 at the moment that the GEAR switch (SW6) is turned off. These negative pulses then invert the FF(1) and FF(2) flip-flops.
- 9) Q303 and Q305 are thus turned off, thereby stopping the tonearm drive motor and size selector solenoid.
- 10) Furthermore, IC303 #9 is switched from (L) to (H) at the same time, but since the shutter of the interrupter (D701 and Q701) is opened by the tonearm moving away from the arm rest, Q701 will be turned on.

- 11) And with Q701 turned on, the collector potential will drop, resulting in the output #12 of the Schmitt trigger (IC305d and e) being switched to (H). This (H) status is then maintained irrespective of the status of #8 and #9.
- 12) When the GEAR switch is turned off, IC304 #13 is switched to (L), thereby stopping the blinking oscillator. IC304 #4 is thus kept at (L) with IC304 #6 at (H), and IC305 #4 is switched to (H), resulting on Q305 being turned on.
- 13) Hence, the PLAY LED blinks on and off while the large gear is rotating (i.e. while the mechanical parts are moving), and stays on continually once play mode has commenced.

3. Reject Operation

When the REJECT button (SW8) is pressed during play

- 1) If the REJECT button is pressed during play mode, IC302 #5 is switched to (L), resulting in #6 being switched to (H).
- 2) And since IC302 #6 is switched to (H), #8 is switched to (L), resulting in the inversion of FF(1) for Q303 to be turned on.
- 3) With this transistor on, the tonearm drive motor is started up.
- 4) The GEAR switch (SW6) is thereby turned on, resulting in the PLAY LED blinking on and off in the same way as during auto start operation.
- 5) The large gear consequently starts to rotate, but by not switching the size selector solenoid on, the mechanical system commences the reject operation.
- 6) When the large gear next stops, negative pulses are generated by IC302 #13 in the same way as described above under play mode. FF(1) is thus inverted, Q303 turned off, and the tonearm drive motor consequently stopped.
- 7) When the GEAR switch (SW6) is turned off, IC304 #6 is switched to (L).
- 8) As a result, IC305 #4 is switched to (L), and Q305 is turned off.
- 9) The PLAY indicator lamp is turned off by Q305 being turned off.
- 10) With the tonearm then returning to the arm rest, the interrupter shutter is closed, resulting in Q701 being turned off. IC303 #8 is switched to (L) when the GEAR switch (SW6) is turned off.
- 11) With IC303 #8 switched to (L), Q801 and Q802 are both turned off, thereby cutting the voltage applied to the Q09 emitter, resulting in the turntable motor being stopped.
- 12) The turntable will now be in the same status as when the power switch (SW1) was turned on.

4. Auto Return Operation

- 1) When the power switch is turned on, the D201 infra-red LED is turned on.
- 2) During the playing of a record the tonearm gradually moves across the record until it comes within the return detector range (57 mm from the center spindle).
- 3) Then when the record groove pitch increases (by entering the lead-out groove) after reaching this detector range, a speed detector is activated, resulting in Q302 being turned on.
- 4) IC302 #6 is then switched to (H), resulting in the tonearm commencing to return to the arm rest in the same way as described above for reject operation.
- 5) Then after completing the same procedure as described for reject operation, the turntable will again be returned to the same status achieved when the power switch was first turned on.

5. Repeat Operation

When the REPEAT button (SW9) is pressed

- 1) When the REPEAT button (SW9) is pressed, the repeat FF is inverted, and the repeat indicator LED is turned on.
- 2) When the tonearm reaches the return detector range and the speed detector circuit is activated, Q302 will again be turned on (as was described for auto return operation).
- 3) IC302 #6 is thus switched to (H), resulting in the tonearm drive motor being started up in the same way as described for reject operation.
- 4) IC302 #1 is also switched to (H), but via IC305 C.
- 5) With the repeat indicator lamp turned on at this time, IC302 #3 is switched to (L) to invert flip-flop FF(2).
- 6) Upon inversion of FF(2), Q304 is turned on, and the size selector solenoid is consequently activated, followed by the same operational sequence as described for auto start operation. The turntable is thus restarted in play mode again.
- 7) Thus, by repeating the above procedure, the turntable will be continually restarted in play mode as long as the repeat indicator LED is on.

6. When the reject button is pressed with the tonearm still on the arm rest.

- 1) IC302 #6 is switched to (H) in the same way as in reject operation.
- 2) However, since IC302 #9 is (H) status, #8 will also be (H) irrespective of the status of #10. There will, consequently, be no activation of the circuit.

7. Speed Detector Circuit

This circuit has been designed to vary the i_2 quantity in response to changes in the Q201 collector voltage (V_{c1}). i_2 is given by the following expression.

$$i_2 = \frac{V_{c1}}{dt} \cdot C301$$

Where i_2 is the current passed via R303.
The current passed via R304 is denoted i_1 .

Due to the movement of the auto return detector shutter (which corresponds to tonearm movement), the amount of light received by Q201 from D201 is gradually increased, resulting in a corresponding drop in collector voltage. Then when the detector shutter movement increases rather sharply, i_2 will approach i_1 , resulting in Q301 finally being turned off. Q302 is thus turned on and the Q302 collector voltage drops, thereby generating the "return signal". Sensitivity may be adjusted by altering the amount of change in i_2 with the same detector shutter speed by using VR301. Furthermore, sensitivity is decreased for 45 rpm record speed by short circuiting the R301 resistor.

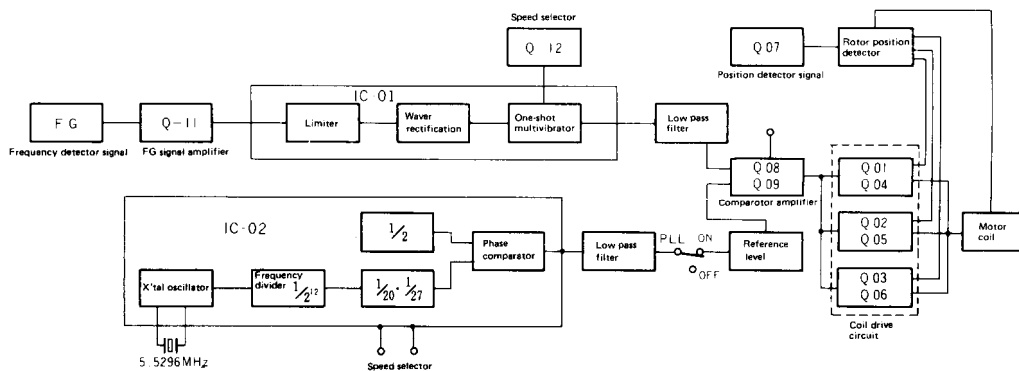
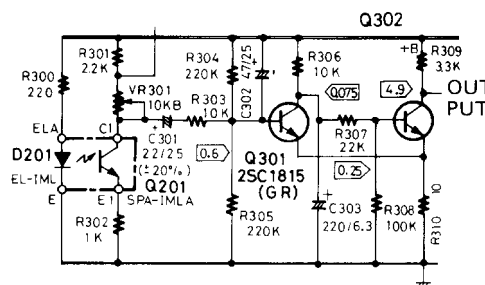

8. Motor Drive Circuit

When the PLAY button is pressed, IC303, # 8 is switched to (H), Q801 and Q802 turned on, and the Q09 control circuit also turned on. One or two of the coil drive circuits is then turned on by the rotor position detector signal, resulting in a current being passed through the motor coil to start up the magnet rotor. Once this rotor has started to rotate, signals generated according to the rotational frequency (FG signals) are detected by the speed detector coil. These signals are then amplified by Q11 and undergo limiter amplification and wave rectification in IC01 before being applied to the one-shot multivibrator and IC02. The multivibrator output is smoothed out by a 3-stage low-pass filter, producing voltage levels in accordance to the FG IN signal frequency (100Hz at 33rpm and 135Hz at 45rpm). In addition, the FG IN signal is also divided by IC02 and applied to a phase comparator where it is compared with a reference signal generated by the crystal oscillator. By obtaining output pulse widths which vary according to the phase differences, and then smoothing these pulse signals, the voltage obtained will be in proportion to the phase difference.

In the case of LOCK ON, the F/V output and the voltage obtained by mixing the PD output with the reference level voltage, are compared and amplified by Q08 and Q09. The output is then used to control the Q01/Q04, Q02/Q05 and Q03/Q06 coil drive circuits.

In the case of LOCK OFF, speed control involves varying the reference level voltage by VR independently of the PD output, the IC02 frequency division ratio is switched to 1/27 for 33rpm, and 1/20 for 45rpm, this being achieved by switching the one-shot multivibrator time constants by Q12.

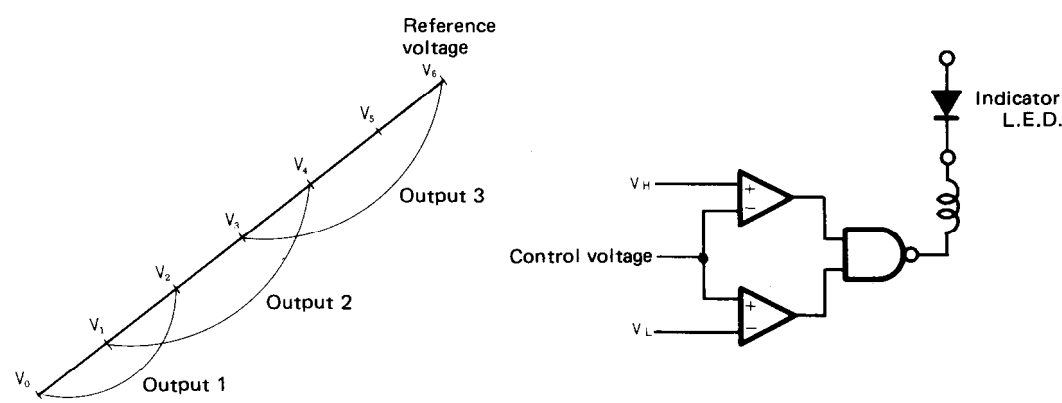
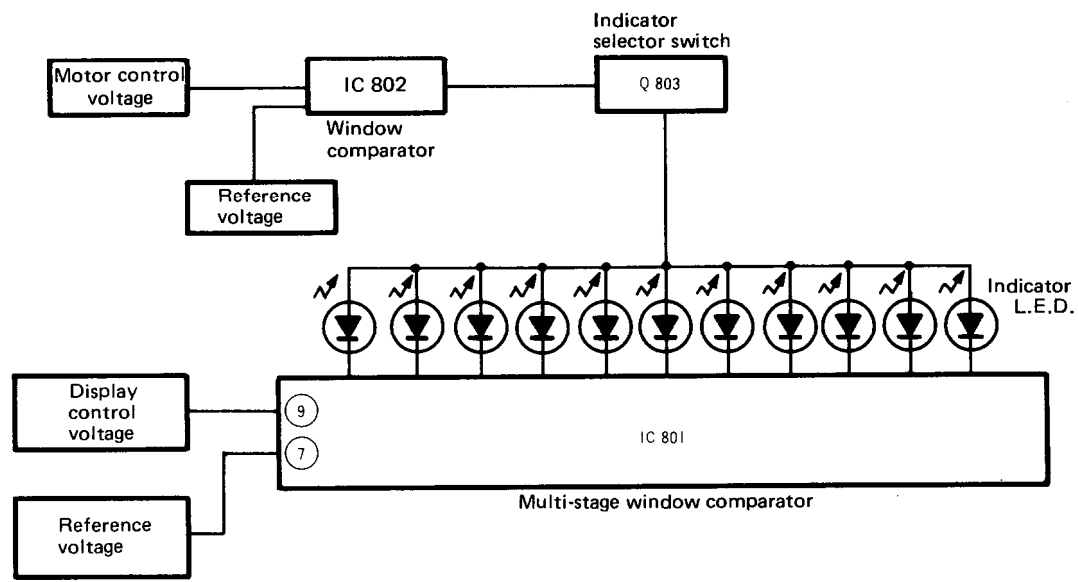

9. Pitch Control Indicator Circuit

The reference voltage for the multi-stage window comparator IC801 is divided into 22 equal portions, and the upper and lower voltage limits are then set for each comparator. Then depending on the window comparator, one or two LEDs will be turned on.

When the display control voltage is in between V_0 and V_1 , comparator output 1 is switched to L, resulting in output 1 LED being turned on. In this case, the window comparator V_L is coupled to V_1 , and V_H to V_2 . Output 2 will still be H at this time, so the corresponding display LED will remain off.

When the input voltage is between V_1 and V_2 , both output 1 and 2 will be switched to L, resulting in two LEDs being turned on. In the V_2-V_3 range, output 1 is switched to H while output 2 remains switched to L. and since the display LED is connected only to output 2 at this time, only one LED will be turned on.

Hence, by varying the display control voltage in a linear manner, the display LEDs will be lit up in succession.

In LOCK OFF position, the display control voltage is obtained by the pitch control VR and the inter-linked VRs (2KΩB) and used as the display control input, resulting in the pitch control display LED being turned on at 1% intervals.

When the turntable motor is started or stopped, when the speed is switched from 45 to 33rpm, and when the turntable is stopped or speeded up forcibly, the display LEDs are turned off by cutting the LED B voltage, this being achieved by turning Q803 off by passing the motor control circuit output via the window comparator with upper limit voltage of 18V and low limit voltage of 11V.

SERVICE PROCEDURES AND ALIGNMENT

1. CAUTIONS

1. This model is used CMOS ICs

Motor p.c.b. IC01 MSM4011RS

IC02 MSM5818RS

Control p.c.b. IC304 TC4011BP

IC305 TC4049P

- 1) All CMOS devices should be stored or transported in materials that are somewhat conductive, MOS devices must not be inserted into conventional plastic "snow" or plastic trays.
- 2) All CMOS devices should be placed on a grounded bench surface and operators should ground themselves prior to handling devices, since a worker can be statically charged with respect to the bench surface.
- 3) Nylon clothing should not be worn while handling CMOS circuit.
- 4) When lead straightening or hand soldering is necessary, provide ground straps for the apparatus used.
- 5) Double check test equipment set up for proper polarity of voltage before conducting parametric or functional testing.
- 6) All unused device inputs should be connected to VDD or Vss.
- 7) If it becomes necessary to replace the switch of NASW-777 (Play, Repeat, Reject) for any reason, it is installed at the correct position as shown in fig. 7.

2. Do not rotate the main motor with the unit turned upside down.

If it becomes necessary to invert the unit for check purposes, first connect the DD ON/OFF terminal in the NADG-773 circuit to ground via a 1K Ω resistor. Turning the main motor while the unit is upside down will damage the shaft bearing and fork, resulting in serious deterioration in the wow and flutter rating.

3. If it becomes necessary to replace the motor drive IC01 (MSM4011RS) for any reason, special attention must be given to the following requirement.

Although this IC (MSM4011RS) is designed for 4-rank utilization and requires timing adjustment when replaced, adequate adjustment may not always be possible. In this case, change the resistance values for R33 and R45.

4. Whenever replacing zener D, interrupter (EL-1ML, SDA-1MLA) MSM5818RS, or MSM4011RS and similar components, always ensure that they are properly adjusted.

5. Attaching the cartridge

Please use the included headshell when attaching the cartridge. The headshell is designed for almost all cartridges on the market today; be careful not to buy a cartridge that is not compatible. In general, cartridges with a mass of 4 – 11 grams should be employed.

Attach the cartridge as shown below, connecting each of the color coded lead wires to the proper terminal. If a mistake is made, no sound will be heard or stereo reproduction will be lost. Also, to prevent damage to the stylus during installation operations, leave its cover on or remove the stylus completely.

Adjust so the distance between the stylus tip and the base of the headshell is 30 mm (1 3/16") and tighten the screw. This assures the effective length and overhang of the tonearm are correct.

Use the include overhang gauge as shown Fig. 9, placing the cartridge in the gauge and setting the location of the stylus tip as indicated.

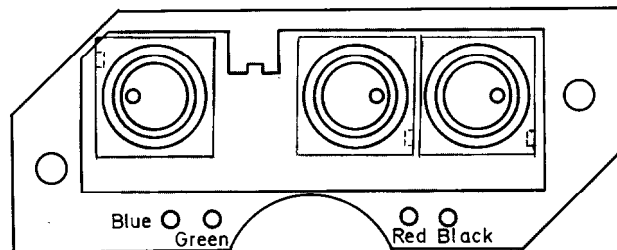

Fig. 7

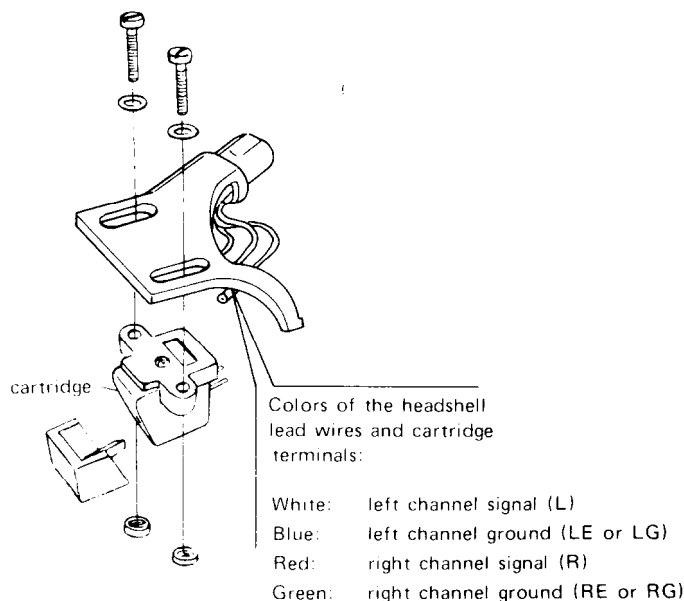

Fig. 8

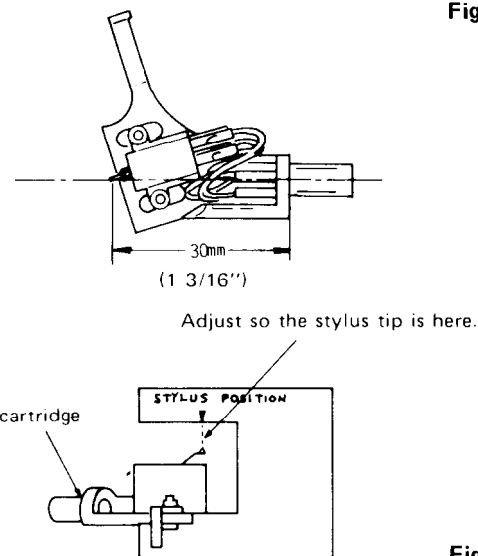

Fig. 9

2. Voltage conversion

Before connecting the unit to an AC outlet, check whether it is set for the local AC voltage. The turntable may be set to operate at either 120V or 220V.

The voltage selector is under the turntable platter. If a voltage change is necessary, remove the lock plate, switch to the proper voltage, and replace the plate. Note that the CP-1280F operates at both 50 and 60Hz power frequencies.

Notice: Some units have been designed to operate only on AC240V 50Hz (or 120V 60Hz), and are consequently not equipped with a voltage selector.

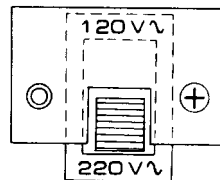

3. Tonearm height

- 1) Remove the turntable mat and move the cueing lever to the down position.
- 2) Press the record size selector to 17 cm position and the power switch to the on position.
- 3) Press the play button to the on position.
- 4) As soon as the tonearm comes over the turntable platter, press the power switch to the off position.
- 5) Adjust the screw (1) for 11mm height between the stylus tip and the turntable platter.
- 6) Move the cueing lever to the up position.
- 7) Adjust the screw (2) for 12mm height between the stylus tip and the turntable platter.

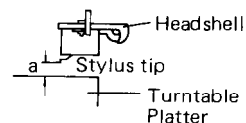
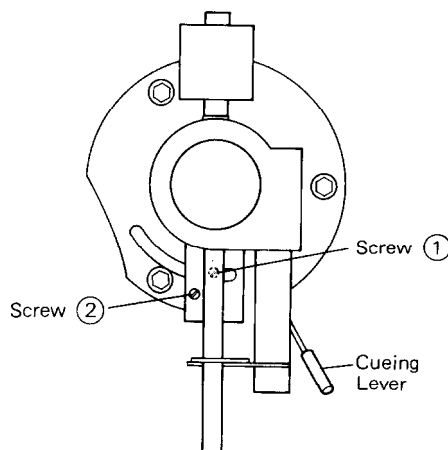

4. Return position adjustment

Connect the DC voltmeter between Cl input of tonearm control p.c.b. and the ground terminals. Adjust VR301 to 0.85V.

Then adjust the return position by the large eccentric pin attached by the tonearm base.

5. Lead-in position adjustment

The lead-in position is adjusted by means of the small eccentric pin attached to the base of the tonearm.

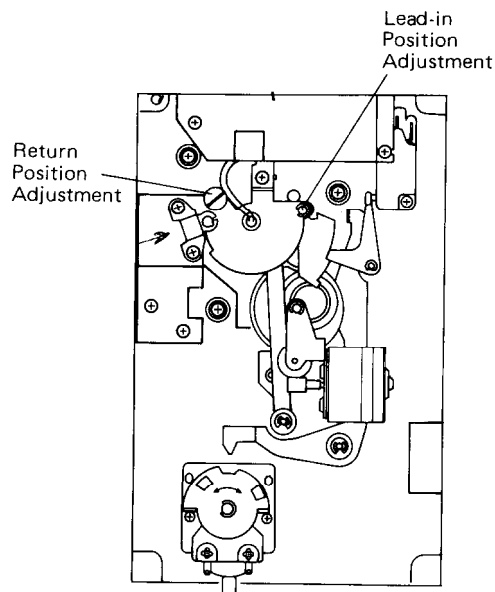

6. Motor control circuit adjustment

- 1) Connect the oscilloscope between TP terminal (Pin nos. 9 of IC02) and ground terminal.
- 2) Set the speed control button to 33rpm position.
- 3) Adjust the VR33 for $t = 0.5\text{msec}$.
- 4) Then the speed button to 45rpm position.
- 5) Adjust the VR45 for $t = 0.5\text{msec}$.
- 6) Repeat steps 3 and 5.

7. Zero indicator and speed adjustment

- 1) Set the quartz locked switch to off position and the speed control variable resistor to mechanical center.
- 2) Adjust the VR 802 so that the zero indicator light up.
- 3) Adjust the VR 801 to 33 1/3 rpm speed.

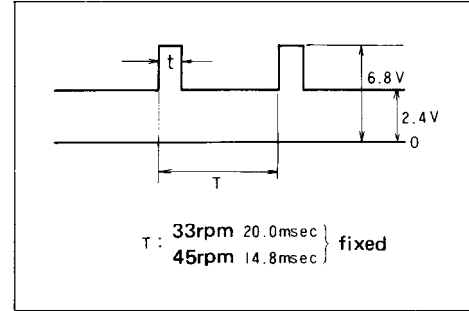

Wave of motor control circuit

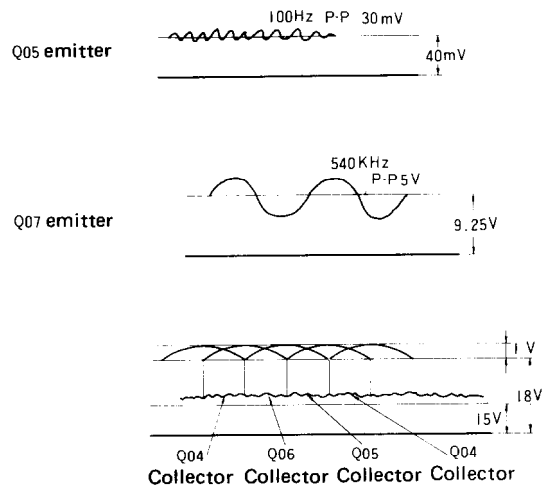
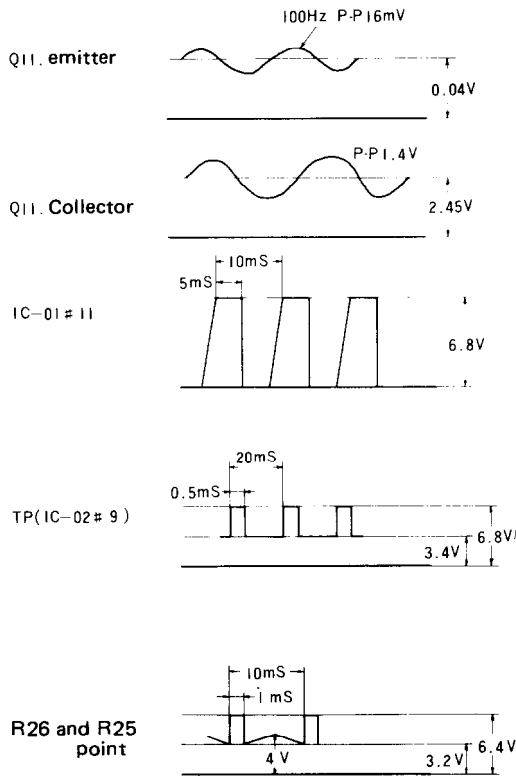

Lock : ON
Speed : 33rpm

REF. NO.	PARTS NO.	DESCRIPTION
1	24504288-1	Operation plate
2	16861575	NADIS-775, Control circuit p.c.b.
3	831130082	35TW + 8BQ, Tapping screw
4	28320379	Knob (L)
5	27180052	Spring for knob
6	271400325A	Bracket for power
7	25035191	NPS-111-L155P, Power switch (D)
8	25035051	NPS-121-L16P, Power switch (W/Q)
9	82113006	3P + 6FN, Pan head screw
8	833130088	3TTP+8B, Tapping screw
10	28320380	Knob (S)
11	25035162	NPS-222-222-L126, push switch
12	16861576	NASW-776, Switch p.c.b.
13	25035180	NPS-144-L144, Push switch
14	16861578	NASW-778, Switch p.c.b.
15	28320381	Knob (PIT)
16		Nut for volume
17		Washer for volume
18	27140326	Bracket (PIT)
19	5147007	N16RG2KB30, Variable resistor
22	25035089	NPS-111-S54, Push switch
23	16799577A	NASW-777a, Switch p.c.b.
24	24504289	Cover for L.E.D.
25	28110176	Cabinet ass'y
26	87613008	W3 x 8, Washer
27	82113018	3P + 18FN, Pan head screw
28	27140383	Bracket (Z)
29	24504290	T.T. base
30	27140329	Bracket (W)
31	82114010	4P + 10FN, Pan head screw
32	24502091	Motor with <i>Control Plate</i>
33	871140	SW-4, Washer
34	82544010	4B + 10FN (BC), Binding screw
35	24506334-1	Chassis
36	24503082	Selector spring
37	24506256	Selector ass'y
38	893032	E-3-2, Circlip
39	24503081	Main gear (2)
40	24503080	Main gear (1)
41	24503083	Gear (1)
42-1	24503084	Gear (2)
42-2	24502084	DC motor with gear (2)
42-3	24506258	Gear (BKT)
42-4	24610125	Rubber stand
42-5	24610124	Collar
42-6	801212	FMT + 2.6 x 6, Pan head screw
43	82113006	FMT + 3 x 6, Tapping screw
44	24506337	Rotation plate
45	24506288	FWS x 15 x 1 ¹ / ₂ , Fiber washer
46	24502079	Friction rubber
47	893040	E-4, Circlip
48	24506260	Switch arm
49	893020	E-2, Circlip
50	24502080A	Solenoid ass'y
50-1	24506261	Sub-chassis
50-2	24506289	Magnet
50-3	24506262	Selector cam
50-4	82112606	FM + 2.6 x 6, Pan head screw
50-5	24506338	W3.1 x 6 x 0.1 ¹ / ₂ , Poly slider washer
50-6	24502081	Spool ass'y R SOLENOID
50-7	82112604	FM + 2.6 x 4, Pan head screw
50-8	24506309	Damper
50-9	24506339	Detector magnet
50-10	371121044	0.1µF, 50V, Mylar capacitor
51	24503040	NMS-1203, Micro switch
52-1	24506348	Phototransistor bracket
52-2	16861579	NASW-779, Switch p.c.b.
52-3	228004	Interrupter
52-4	27225053	Shielded case
53	82112606	2.6P + 6FN, Pan head screw
54	82112615	2.6P + 15FN, Pan head screw
55		Arm base ass'y
55-1	24506390	Arm base ass'y (2)
55-2	24506344A	Eccentric pin (1)
55-3	24506142	Circlip
55-4	24503094	Spring for tonearm
55-5	24506389	Eccentric pin (3)
55-6	24506346	Slit for tonearm
56	82113006	3P + 6FN, Pan head screw
57	834130062	3STS + 6BQ, Tapping screw
58	24509202A	Sensor ass'y
58-1	24506394	Stand (2)
58-2	24506335	Sensor holder
58-3	226002	SPA-1MLA (1), Phototransistor
58-4	225042	EL-1ML, L.E.D.
59	24505111	Output cord
60	27270049	Spacer
61	86213010	WN3 x 10FN, Nut
62	85143116	W3.1 x 16FN, Wood screw
63	27140328	Bracket for tonearm
64	801197	8W3P + 20FN, Screw
65	24610125	Cushion
66	863130	N-3F-N, Nut
67	230363	NPT-693D, Power transformer (D)
	230364	NPT-693DG, Power transformer (W)
	230393	NPT-693Q, Power transformer (Q)
68	834140102	4STS + 10BQ, Tapping screw
69	16799573B	NADG-773b, Control p.c.b. (D)
	16800573C	NADG-773c, Control p.c.b. (W/Q)
70	16799574A	NAPS-774a, Power supply p.c.b. (D)
	16800574B	NAPS-774b, Power supply p.c.b. (W/Q)
71		Motor control p.c.b.
72	253099A	AS-UC-3, Power supply cord (D)
	253083	AS-CEE, Power supply cord (W)
	253104	Power supply plug (Q)
	728320	Power supply cord (Q)
73	270025	SR-3P-4, Strainrelief (D)
	270280	SR-4K-4, Strainrelief (W/Q)
	27140385	Bracket (AC)
75	24501288	Tonearm

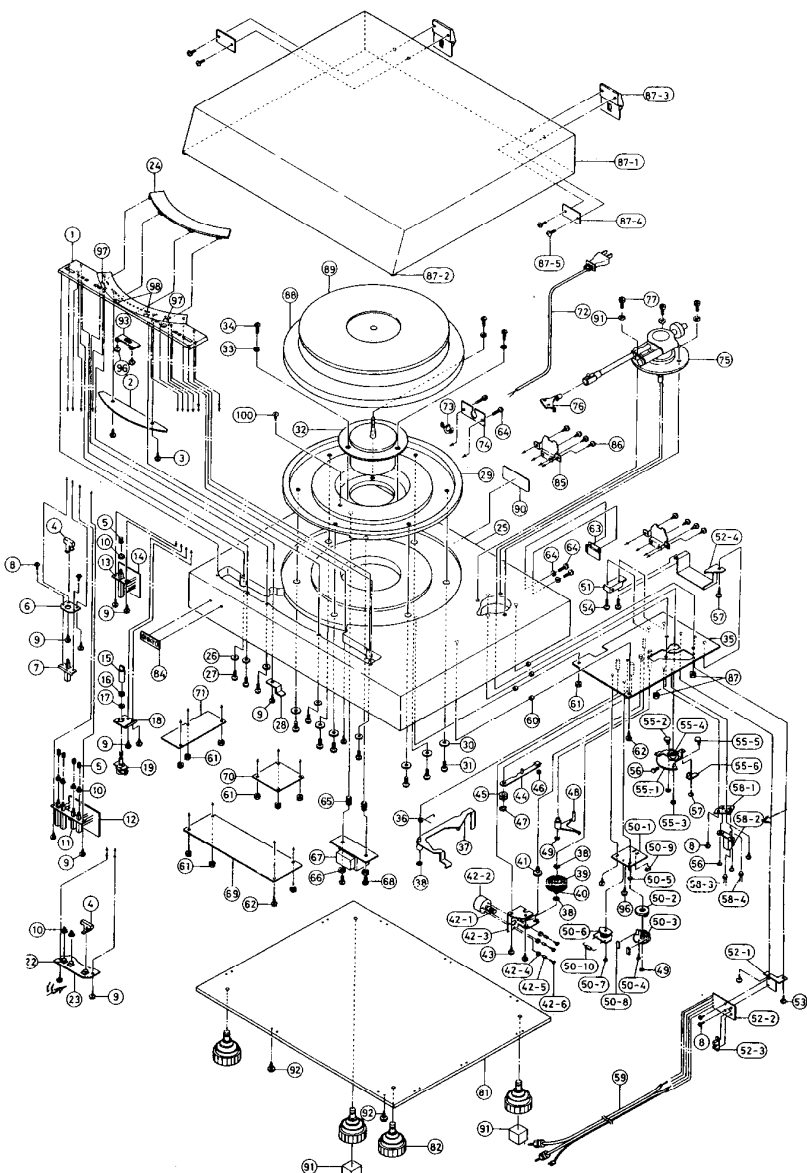

CP 12804

REF. NO.	PARTS NO.	DESCRIPTION
76	24501262	Headshell
77	84345020	5HB + 20FN (BC), Hexagone bolt
81	27170075-1	Bottom board
82	24509211	Leg
84	28135064	Badge
85	24509120	Plate (D)
	24506136	Plate (W/Q)
86	85143113	M3.1 x 13F (BC), Wood screw
87	24509203	Dust cover ass'y
87-1	24509182	Dust cover
87-2	24509184	Cushion
87-3	28180060	Hinge
87-4	28180061	Plate for hinge
87-5	82544010	4B + 10FN (BC), Screw
88	24502090	Turntable platter
89	24509183-1	T.T. mat
90	29360357	Rating label (D)
	29360539	Rating label (W/D)
91	870069	W5 x 10, Nylon washer
92	833130164	35TP + 16A, Tapping screw
93	27140384	Bracket (K)
94	28140257	Mounting stud
95	86414010	WN4 x 10FN, Screw
96	838130062	BT + 3 x 6, Tapping screw
97	28140230	Cushion
98	28140231	Cushion
99	28140223	6 x 14 x 6.5, Cushion
100	85143316	M3.1 x 16FN (BC), Screw
	821430082	35TW + 6FN (BC), Pan head screw for voltage selector (W)
	270444	Switch fixtured plate (W)
	25065106	NSS-2553, Voltage selector switch (W)

PRINTED CIRCUIT BOARD-PARTS LIST

CONTROL CIRCUIT PC BOARD

(NADG-773)-PARTS LIST

CIRCUIT NO.	PARTS NO.	DESCRIPTION
	ICs	
IC301	222439 222481 or	SN7410N or HD7410
IC302, IC303	222425 222478 or	SN7400N or HD7400
IC304	222528 or	μ PD4011C or
IC305	222513 222475	TC4011BP TC4049P
	Transistors	
Q301, Q302	2211255	2SC1815(GR)
Q303, Q304	2211705 or	2SD655(E) or
Q305	2211706	2SD655(F)
Q901, Q902	2211255 2201074	2SC1815(GR) 2SD880(Y)
	Diodes	
ZD901	224092	RD20E(B)
ZD902	223947	RD5.6E(B)
ZD903	223963	RD12E(B)
D301	223839	1N4002
D302, D304	223105	1S1555
D901	223862	WL01
	Resistors	
R903	441622714	270 Ω , 1W, Metal oxide film
VR301	5225015	N10HR10KBD, Semi-fixed
	Capacitors	
C301, C303	352744701	47 μ F, 16V, Elect.
C302	352754701	47 μ F, 25V, Elect.
C320	352950226	2.2 μ F, 25V, Non-polar elect.
C901	352754711	470 μ F, 25V, Elect.
C902	352761021	1,000 μ F, 35V, Elect.
C903	352764701	47 μ F, 35V, Elect.
C904	352762201	22 μ F, 35V, Elect.
C905, C906	352754701	47 μ F, 25V, Elect.
C907	352753301	33 μ F, 25V, Elect.
	Fuseholder	
	250113	120V model
	25050052	W/Q model
	Fuse	
F901	252045 252070	1A-ST-6, 120V model 1A-SE-EAK, W/Q model
	Radiator	
	27160029	

POWER SUPPLY PC BOARD

(NAPS-774)-PARTS LIST

CIRCUIT NO.	PARTS NO.	DESCRIPTION
C900	3500057	125V, 103M, CS capacitor, 120V model
C900	3500058	PME265MB510, IS capacitor, W/Q model

DISPLAY CIRCUIT PC BOARD

(NADIS-775)-PARTS LIST

CIRCUIT NO.	PARTS NO.	DESCRIPTION
	ICs	
IC801	222587	M51901P
IC802	222465	NJM4558D
	Transistors	
Q801	2211254 2211255 or	2SC1815(Y) 2SC1815(GR) or
Q802, Q803	2210803, 2211453 or 2211454	2SA733(P), 2SA1015(O) or 2SA1015(Y)
	L.E.Ds	
	225040	REDSLC-26RU
	225041	GRNSLC-26GG
	Resistors	
VR801	5225015	N10HR1KB
VR802	5225019	N10HR4.7KB
	Capacitors	
C802	352752201	22 μ F, 25V, Elect.
C803	352743301	33 μ F, 16V, Elect.

SWITCH CIRCUIT PC BOARD

(NASW-776)-PARTS LIST

CIRCUIT NO.	PARTS NO.	DESCRIPTION
D401	222802, 223848 or	1S1885, GP08B or 1N4002
S401	223839 25035162	Diode NPS-222-222-L134, Push switch

SWITCH PC BOARD

(NASW-777a)-PARTS LIST

CIRCUIT NO.	PARTS NO.	DESCRIPTION
P502	27150110	Shielded plate
S501	25035089	NPS-111-S54, Push switch

SWITCH CIRCUIT PC BOARD

(NASW-778)-PARTS LIST

CIRCUIT NO.	PARTS NO.	DESCRIPTION
S601	25035180	NPS-144-144, Push switch

SWITCH PC BOARD

(NASW-779)-PARTS LIST

CIRCUIT NO.	PARTS NO.	DESCRIPTION
Q701	226004	ON1122, Interrupter

MOTOR CONTROL PC BOARD-PARTS LIST

CIRCUIT NO.	PARTS NO.	DESCRIPTION
	ICs	
IC01		MSM-4011RS
IC02	222590	MSM-5818RS
	Transistors	
Q01~Q03	2210803 2211453 or	2SA733(P) 2SA1015(O) or
Q04~Q06	2211612 2211611 or	2SD471(L) 2SD471(K) or
Q07, Q08	2210743 or	2SC945(P) or
Q11, Q12	2210744 or	2SC945(Q) or
Q09	2211140	2SA798
	Diode	
ZD0	223961	RD6.8E-B2
	X'tal	
	3010047	5.5296MHz
	Semi-fixed resistor	
VR45	5225037	N10HR220KBD
VR33	5225078	N10HR47KBD

SCHEMATIC DIAGRAM

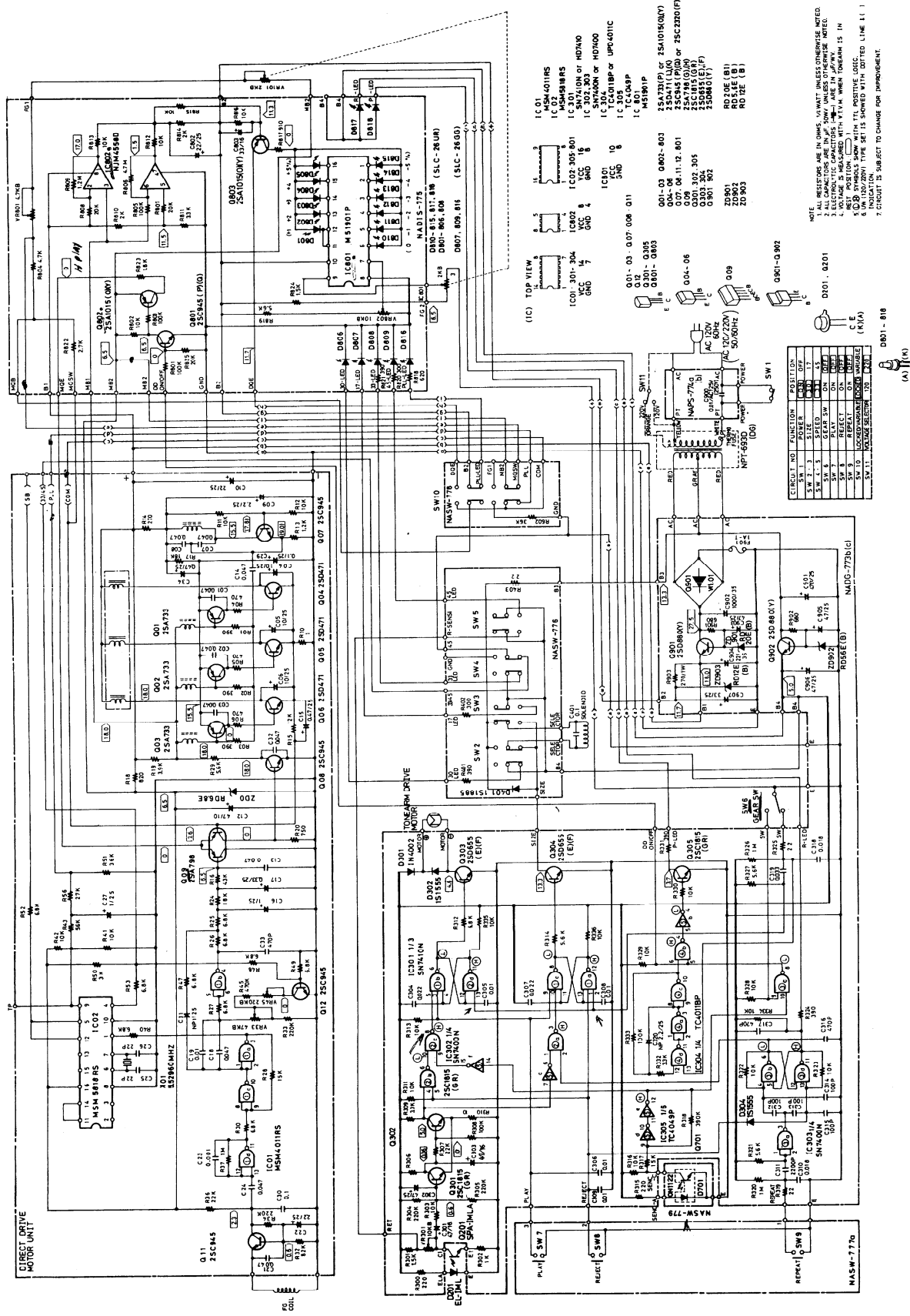

PARTS LIST

120V model

REF. NO.	PARTS NO.	DESCRIPTION
69	16799573B	NADG-773b, Control circuit p.c.b.
70	16799574A	NAPS-774a, Power supply p.c.b.
2	16861575	NADIS-775, Display circuit p.c.b.
12	16861576	NASW-776, Switch circuit p.c.b.
23	16799577A	NASW-777a, Switch circuit p.c.b.
14	16861578	NASW-778, Switch circuit p.c.b.
52-2	16861579	NASW-779, Switch circuit p.c.b.
	225040	SLC-26UR RED, L.E.D. for speed indicator
	225041	SLC-26GG GREEN, L.E.D. for indicator
	225042	EL-1ML, L.F.D. for return detector
Q201	226002	SPA-1MLA, Phototransistor
42-2	24502084	DC motor with gear
50	24502080A	Record size selector solenoid ass'y
32	24502091	Motor with motor control circuit p.c.b.
67	230363	NPT-693D, Power transformer
SW101	25035191	NPS-111-L155P, Power switch
51	24503040	NMS-1203, Microswitch
19	5147007	N16RG2KB30, Speed control variable resistor
72	253099A	AS-UC-3, Power supply cord
59	24505111	Output cord
58	24509202A	Sensor ass'y
40	24503080	Main gear (1)
39	24503081	Main gear (2)
42-3	24506258	Gear (BKT)
41	24503083	Gear (1)
42-1	24503084	Gear (2)
46	24502079	Friction rubber
45	24506288	FW5 x 13 x 1, Fiber washer
50-3	24506262	Selector cam
50-9	24506339	Detector for magnet
50-6	24502081	Spool ass'y
55-1	24506390	Tonearm base (2)
55-2	24506344A	Eccentric pin (1)
55-5	24506389	Eccentric pin (3)
25	28110176	Cabinet ass'y
84	28135064	Badge
87	24509203	Dust cover ass'y
87-3	28180060	K-1757, Hinge
87-4	28180061	Plate for hinge
81	27170075-1	Bottom board
82	24509211	leg
1	24504288-1	Cover for operation
24	24504289	Cover for L.E.D.
29	24504290	Base for turntable platter
4	28320379	Knob (L)
10	28320380	Knob (S)
15	28320381	Knob (PIT)
	28140236	Cushion for knob (L)
	28140237	Cushion for knob (S)
73	270025	SR-3P-4, Strainrelief
	28140234	Cushion for NADG-773b
88	24502090	Turntable platter
75	24501288	Tonearm ass'y
	24501247	Screw for tonearm
	24501262	Headshell
	24501309	Counter weight
	24501292	Screw for cartridge
	24501293	Nut for cartridge
	24500079	Washer for cartridge
	24501301	Spacer for headshell
90	29360357	Rating label

W/Q model

REF. NO.	PARTS NO.	DESCRIPTION
69	16800573C	NADG-773C, Control circuit p.c.b.
70	16800574B	NAPS-774B, Power supply p.c.b.
2	16861575	NADIS-775, Display circuit p.c.b.
12	16861576	NASW-776, Switch circuit p.c.b.
23	16799577A	NASW-777a, Switch circuit p.c.b.
14	16861578	NASW-778, Switch circuit p.c.b.
52-2	16861579	NASW-779, Switch circuit p.c.b.
	225040	SLC-26UR RED, L.E.D. for speed indicator
	225041	SLC-26GG GREEN, L.E.D. for indicator
	225042	EL-1ML, L.E.D. for return detector
Q201	226002	SPA-1MLA, Phototransistor
42-2	24502084	DC motor with gear
50	24502080A	Record size selector solenoid ass'y
32	24502091	Motor with motor control circuit p.c.b.
67	250364	NPT-693DG, Power transformer (W)
	230393	NPT-693Q, Power transformer (Q)
SW101	25035051	NPS-121-L16P, Power switch
51	24503040	NMS-1203, Microswitch
19	5147007	N16RG2KB30, Speed control variable resistor
72	253083	AS-CEE, Power supply cord (W)
	253104	Power supply cord (Q)
	728320	AC plug (Q)
59	24505111	Output cord
58	24509202A	Sensor ass'y
40	24503080	Main gear (1)
39	24503081	Main gear (2)
42-3	24506258	Gear (BKT)
41	24503083	Gear (1)
42-1	24503084	Gear (2)
46	24502079	Friction rubber
45	24506288	FW5 x 13 x 1, Fiber washer
50-3	24506262	Selector cam
50-9	24506339	Detector for magnet
50-6	24502081	Spool ass'y
55-1	24506390	Tonearm base (2)
55-2	24506344A	Eccentric pin (1)
55-5	24506389	Eccentric pin (3)
25	28110176	Cabinet ass'y
84	28135064	Badge
87	24509203	Dust cover ass'y
87-3	28180060	K-1757, Hinge
87-4	28180061	Plate for hinge
81	27170075-1	Bottom board
82	24509211	Leg
1	24504288-1	Cover for operation
24	24504289	Cover for L.E.D.
29	24504290	Base for turntable platter
4	28320379	Knob (L)
10	28320380	Knob (S)
15	28320381	Knob (PIT)
	28140236	Cushion for knob (L)
	28140237	Cushion for knob (S)
73	270280	SR-4K-4, Strainrelief
	28140234	Cushion for NADG-773C
88	24502090	Turntable platter
75	24501288	Tonearm ass'y
	24501247	Screw for tonearm
	24501262	Headshell
	24501309	Counter weight
	24501292	Screw for cartridge
	24501293	Nut for cartridge
	24500079	Washer for cartridge
	24501301	Spacer for headshell
90	29360357	Rating label
	25065106	NSS-2253P, Voltage selector slide switch (W)
	270444	Voltage fixtured plate (W)

PACKING PROCEDURES

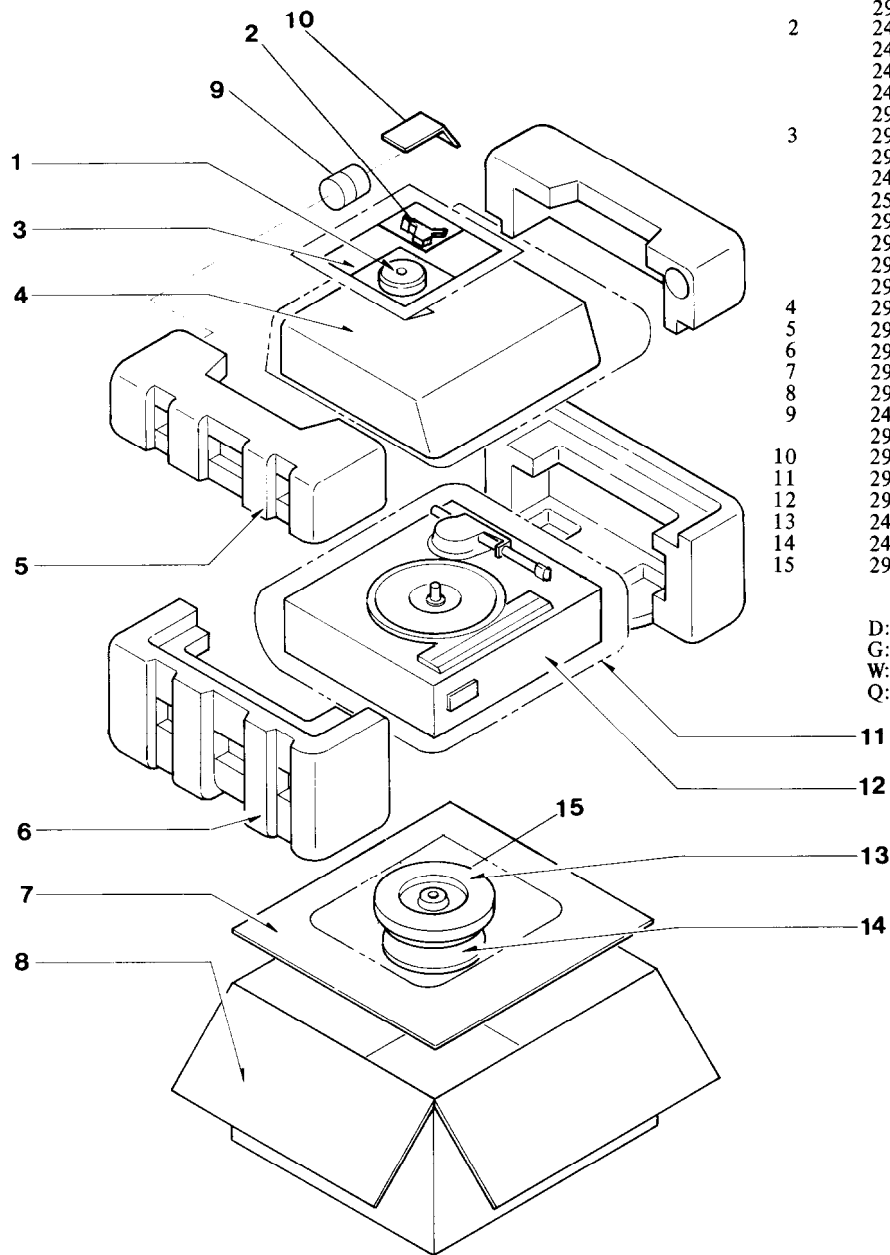

REF. NO.	PARTS NO.	DESCRIPTION
1	292049A	45 rpm adaptor
	29100002	80 x 150mm, Poly bag
2	24501262	Headshell
	24501292	Screw for headshell
	24501293	Nut for headshell
	24500079	Washer for headshell
	29100002	80 x 150mm, Poly bag
3	29340409	Instruction manual (D)
	29340410	Instruction manual (G, W/Q)
	24509197	Overhang gauge
	25055018	Conversion plug (W/G)
	29358002	Service station list (D)
	29365006	Warranty card (D)
	29365005-1	Warranty card (G)
	29100005	Poly bag
4	29100047	Protection sheet
5	29090490	Pad (U)
6	29090491	Pad (D)
7	29090492	Pad sheet
8	29050347	Master carton box
9	24501309	Counter weight
	29100002	80 x 150mm, Poly bag
10	29095124	Pad sheet
11	29100033A	750 x 650mm, Poly bag
12	29095108-1	650 x 1,000mm, Protection sheet
13	24502090	Turntable platter
14	24509183-1	T.T. mat
15	29100046	370 x 470mm, Poly bag

D: Only 120V model
 G: Only Germany model
 W: 120/220V model
 Q: Only England model

ONKYO CORPORATION

International Division: No. 24 Mori Bldg., 23-5, 3-chome, Nishi-Shinbashi, Minato-ku, Tokyo, Japan
 Telex: 2423551 ONKYO J. Phone: 03-432-6981

ONKYO U.S.A. CORPORATION

Eastern Office
 42-07 20th Avenue, Long Island City, New York 11105, U.S.A. Phone: (212) 728-4639
 Midwest Office
 935 Sivert Drive, Wooddale, Illinois 60191, U.S.A. Phone: (312) 595-2970

ONKYO DEUTSCHLAND GMBH, ELECTRONICS

8034 München-Germering, Industriestrasse 18, West Germany. Telex: 521726 Telefon: (089)-84-5041