



Deze download wordt u gratis aangeboden door Pick-upnaalden.nl

Web : [www.pickupnaalden.com](http://www.pickupnaalden.com)  
Email : [info@pick-upnaalden.nl](mailto:info@pick-upnaalden.nl)  
Facebook : [www.facebook.com/pickupnaalden](http://www.facebook.com/pickupnaalden)  
Twitter : [twitter.com/Pickupnaalden](http://twitter.com/Pickupnaalden)  
Google+ : [https://plus.google.com/+FCaris\\_pickupnaalden](https://plus.google.com/+FCaris_pickupnaalden)

# ONKYO® SERVICE MANUAL

## QUARTZ LOCKED DIRECT DRIVE FULLY AUTOMATIC TURNTABLE

### MODEL CP-1150F



#### TABLE OF CONTENTS

Item	Page
Specifications	2
Service guide	2
Packing procedures	4
Component location	5
Printed circuit board view	6
PC board-parts list	7
Schematic diagram	9
Adjustment procedures	11

**ONKYO®**  
**AUDIO COMPONENTS**

## SPECIFICATIONS

<b>Type:</b>	Direct drive fully automatic turntable auto lead-in and return; reject, repeat, search and cue by button function; two motor micro-computer design.	<b>Tracking Force:</b>	0 – 3.0 grams
<b>Turntable platter:</b>	310 mm (12-1/4") aluminum die-cast, 1,3 kg (3 lbs.) (with platter mat)	<b>Other Features:</b>	Tracking force direct readout scale Removable headshell Slide-type anti-skating control
<b>Motor:</b>	Quartz lock DD motor	<b>Power Supply:</b>	AC 120 V 50/60 Hz, AC 110-120/ 220-240 V 50/60Hz
<b>Speeds:</b>	33-1/3, 45 rpm,	<b>Power Consumption:</b>	24 Watts (Max.) 10 Watts (Normal)
<b>Wow &amp; Flutter:</b>	less than 0.025% (WRMS)	<b>Dimensions (WxDxH):</b>	418 x 380 x 130 mm (16-1/2" x 15" x 5-1/8")
<b>Signal-to-Noise Ratio:</b>	better than 75 dB (DIN B)	<b>Weight:</b>	6.5 kg (14.3 lbs.)
<b>Tonearm:</b>	Statically balanced straight type, carbon fiber/pipe construction	<b>Accessories:</b>	Headshell, counterweight, overhang gauge, adapter, instruction manual
<b>Effective Arm Length:</b>	224 mm (8-7/8")	<b>Cabinet Composition</b>	
<b>Overhang:</b>	13 mm (1/2")	<b>Turntable Cabinet:</b>	Plastic
<b>Offset Angle:</b>	21 degrees	<b>Bottom Panel:</b>	Plastic (ABS)
<b>Maximum Tracking Error:</b>	+3 degrees, -1 degrees	<b>Dust Cover:</b>	Polystyrene
<b>Suitable Cartridge Weight:</b>	Min. 5, Max. 9 grams	<b>Optional Recommended Headshell SH-21E</b>	
			Specifications are subject to change for further product improvements.

## SERVICE GUIDE

## 1. Cautions

- The digital circuit PC board (NADG-910) is used the printed resistors. The surface is strong, but it is not damaged with driver etc. If it becomes necessary to replace the printed resistor for any reason, cut the printed resistor with cutter, and add the same rating solid resistor.
- Do not rotate the main motor with the unit turned upside down. If it becomes necessary to invert the unit for check purposes, remove the socket of main motor.

## 2. Replacing the fuse

Remove the bottom board. The fuse is located on the digital circuit PC board.

Note: For continued protection against fire hazard, replace only with same type and same rating fuse.

Part No.	Description
252046	1.5A-ST-6 (Only 120 V model)
252073	1.6A-SE-EAK (Only Universal model)

## 3. Voltage selector (Universal model)

The voltage selector is located on bottom of the cabinet. If a voltage change is necessary, change the voltage selector switch to the proper voltage.

## 4. Precision Platter Sheet

This platter sheet is precision molded using a special type of plastic that improves platter-to-disc interface characteristics. Always handle the sheet with care to avoid scratching the mirror-finished surface.

## Cleaning

- Wipe the surface with damp cotton.
- While the surface is still damp, wipe off the surface of the sheet with a velvet record cleaning cloth using a circular could electric charges so that dust and dirt particles do not stick to the sheet. This chemical may appear on the surface of the sheet at times, but it has no effect on records. If it detracts from the appearance of the platter sheet, wipe it off using the method described above.

110 – 120 V ~

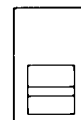

220 – 240 V ~

## 5. Attaching the cartridge

Attach the cartridge as shown below, connecting each of the color coded lead wires to the proper terminal. If a mistake is made, no sound will be heard or stereo reproduction will be lost. Also, to prevent damage to the stylus during installation operations, leave its cover on or remove the stylus completely.

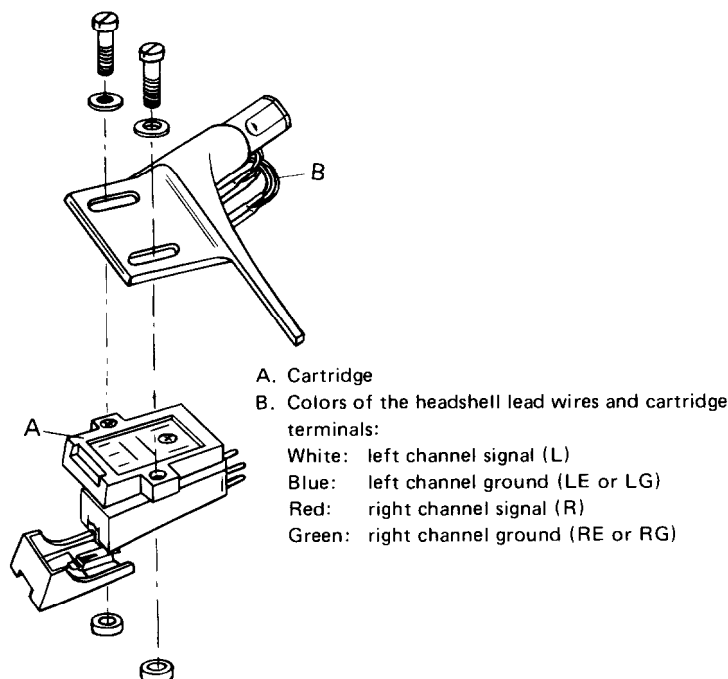

Adjust so the distance between the stylus tip and the base of the headshell is 30 mm (1 3/16") and tighten the screws. This assures the effective length and overhang of the tonearm are correct.

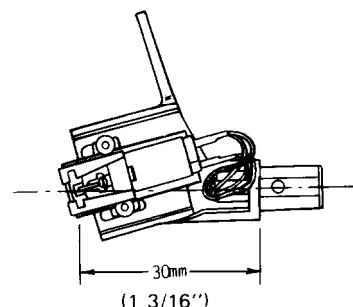

Use the included overhang gauge as shown below, placing the cartridge in the gauge and setting the location of the stylus tip as indicated.

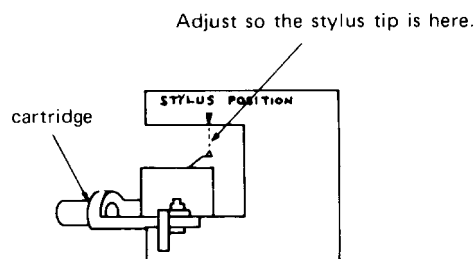

After attaching a different cartridge, always balance the tonearm again and set the appropriate tracking force.

## 6. Search Operation

When the Search Button is depressed, the tonearm rises and slowly moves over the record toward the center stopping when the button is released. Depress the Cue Button to lower the tonearm to the record surface and start record play. If the Search Button is depressed only once, the tonearm will move to the innermost grooves of the record; if depressed once more, the tonearm will return to the outermost grooves. Use the Search Button to simplify manual operation.

## 7. Remote Control

This unit is equipped with a jack so that the RC-5T remote control unit (sold separately) can be used to perform the following tuntable operations from the comfort of your listening position.

- 1) Play/Reject
- 2) Cue (UP/DOWN)
- 3) Search (IN/OUT)
- 4) Repeat

## 8. Memory Repeat

The memory repeat function is used to repeatedly play a record from a desired selection. Read the following instructions carefully to assure correct operation.

1. Start the memory repeat function only with the tonearm still in the arm rest. If memory repeat is operated during record play, the tonearm will repeatedly play the record from the beginning.
2. Using the Search Button, move the tonearm until it is directly over the section where record play is to be repeated.
3. Depress the Repeat Button to the Repeat position.
4. Depress the Cue Button to lower the tonearm onto the record and memory repeat operation will begin. Note that if the Cue Button is depressed before the Repeat Button, normal repeat operation (i.e., from the beginning of the record) will begin.

Note: Memory repeat can be used for any section of the record from the outer edge (set by the record size selector) to the innermost grooves.

## PACKING PROCEDURES

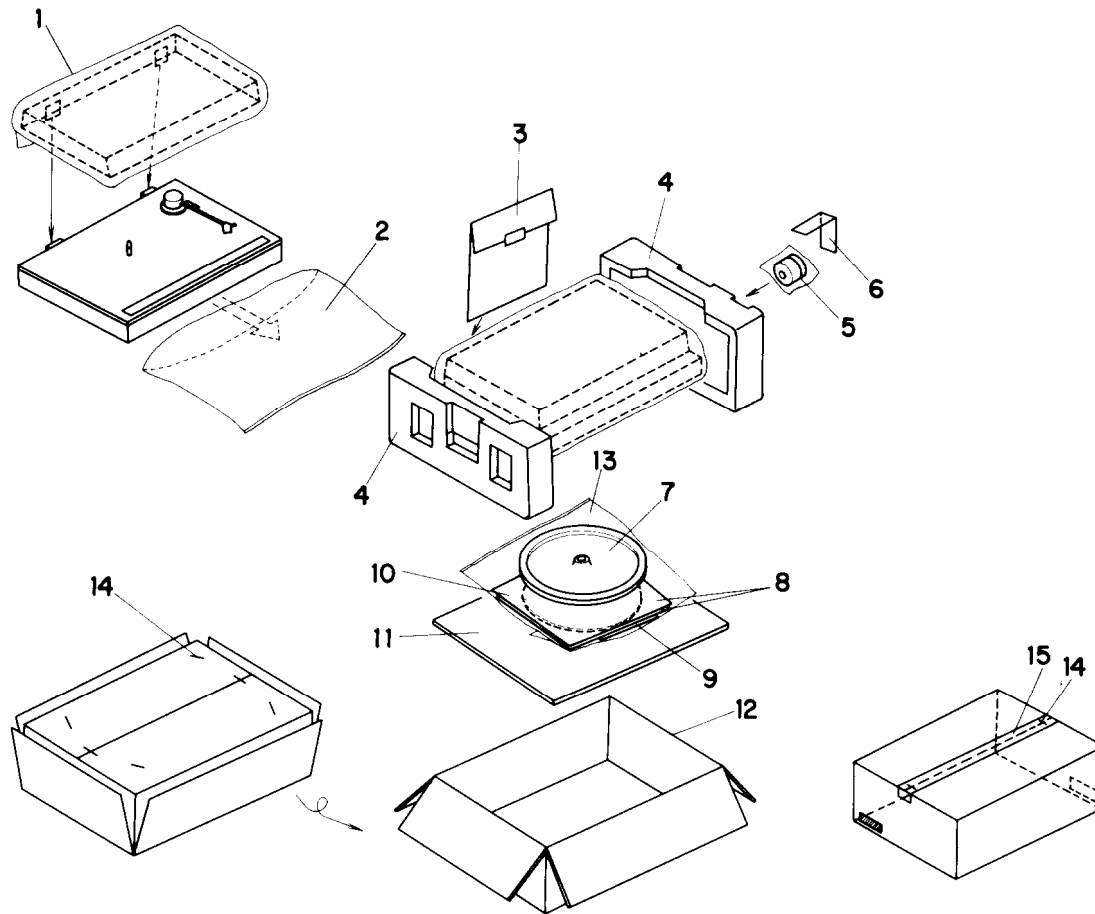

REF. NO.	PARTS NO.	DESCRIPTION
1	29100050	Protection bag
2	29100049	640×620mm, Poly bag
3	292049A	45 rpm adaptor
	24509197	Overhang gauge
	28199039	Film for T.T. sheet
	29340448	Instruction manual (120V model)
	29340447	Instruction manual (Universal model)
	29365006	Warranty card (U.S.A. model)
	29365005-3	Warranty card (Germany model)
	29358002	Service station list (U.S.A. model)
	24501330	Mounting screw for cartridge
	25055018	CV-K-1, Conversion plug (Universal model)
	29100005	220×330mm, Poly bag
4	29090536	Pad
5	24501333	Counter weight
	29100002	80×150mm, Poly bag
6	260013	50×110mm, Tape
7	24502108	Turntable platter
8	29095161	Protection sheet for T.T. mat
9	29355065	Caution sheet
10	24509231	T.T. mat
11	29090526	Pad sheet
12	29050384	Master carton box
13	29100046	370×470mm, Poly bag
14	282301	Sealing hook
15	260012	W50mm, Tape

## COMPONENT LOCATION

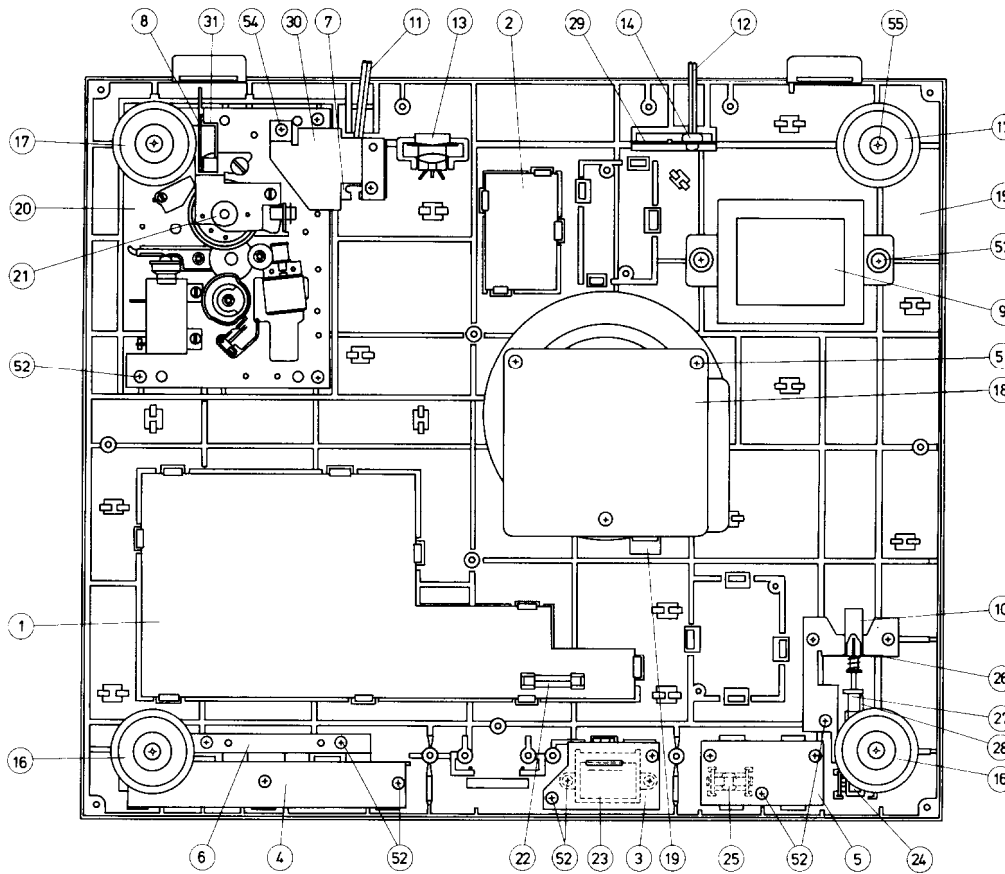

## Universal model

REF. NO.	PARTS NO.	DESCRIPTION
1	16740510A	NADG-910a, Digital circuit pc board ass'y
2	16740511A	NAPS-911a, Power supply pc board ass'y
3	16739512	NADIS-912, Power indicator pc board ass'y
4	16739513	NASW-913, Switch pc board ass'y
5	16739514	NASW-914, Switch pc board ass'y
6	16739515	NACOV-915, Cover pc board ass'y
7	16739516	NAPI-916, Tonearm terminal pc board ass'y
8	15739517	NARET-917, Return pc board ass'y
9	230400	NPT-709AG, Power transformer
10	25035216	NPS-121-L180P, Power switch
11	24505127	Output cable
12	253083	AS-CEE, Power supply cable
13	25050045	NSCT-7P14, Remote terminal
14	270280	SR-4K-4, Strainrelief
15	28110185	Cabinet
	27262068	Plate (R)
	27262069	Plate (L5)
16	24509216-2	Leg
17	24509216-3	Leg
18	24502109	Motor with control pc board
19	25050067	NSAS-5P035, 5P socket
20	24506450A	Mechanism ass'y

## 120V model

REF. NO.	PARTS NO.	DESCRIPTION
1	16739510	NADG-910, Digital circuit pc board ass'y
2	16739511	NAPS-911, Power supply pc board ass'y
3	16739512	NADIS-912, Power indicator pc board ass'y
4	16739513	NASW-913, Switch pc board ass'y
5	16739514	NASW-914, Switch pc board ass'y
6	16739515	NACOV-915, Cover pc board ass'y
7	16739516	NAPI-916, Tonearm terminal pc board ass'y
8	15739517	NARET-917, Return pc board ass'y
9	230399	NPT-709D, Power transformer
10	25035191	NPS-111-L155P, Power switch
11	24505127	Output cable
12	253099A	AS-UC-3, Power supply cable
13	25050045	NSCT-7P14, Remote terminal
14	270025	SR-3P-4, Strainrelief
15	28110185	Cabinet
	27262068	Plate (R)
	27262069	Plate (L5)
16	24509216-2	Leg
17	24509216-3	Leg
18	24502109	Motor with control pc board
19	25050067	NSAS-5P035, 5P socket

21	24501332	Tonearm
	24501321A	Screw for headshell
	24501325	Headshell
	24501333	Counter weight
22	252073	1.6A-SE-EAK, AC fuse
23	28191063	Clear plate
	28133031	Back plate
24	28320447	Knob
25	28320446	Knob
26	27140409	Bracket for power
27	24504305	Cam
28	27180062	Spring
29	27140393	Bracket for power supply cable
30	27150120	Shielded plate
31	27140411	Bracket for interruptor
51	833140120	4TTP+12P, Tapping screw
52	834130100	3TTS+10P, Tapping screw
53	28140209	Cushion
	87614012	W4x12F, Washer
	27265035	Ring
	833140200	4TTP+20P, Tapping screw
54	834130082	3STS+8BQ, Tapping screw
55	833140120	4TTP+12P, Tapping screw
	24509215	Dust cover
	28180062	Hinge
	27170086	Bottom board

20	24506450A	Mechanism ass'y
21	24501332	Tonearm
	24501321A	Screw for headshell
	24501325	Headshell
	24501333	Counter weight
22	252046	1.5 AST-6, AC fuse
23	28191063	Clear plate
	28133031	Back plate
24	28320447	Knob
25	28320446	Knob
26	27140409	Bracket for power
27	24504305	Cam
28	27180062	Spring
29	27140393	Bracket for power supply cable
30	27150120	Shielded plate
31	27140411	Bracket for interruptor
51	833140120	4TTP+12P, Tapping screw
52	834130100	3TTS+10P, Tapping screw
53	28140209	Cushion
	87614012	W4x12F, Washer
	27265035	Ring
	833140200	4TTP+20P, Tapping screw
54	834130082	3STS+8BQ, Tapping screw
55	833140120	4TTP+12P, Tapping screw
	24509215	Dust cover
	28180062	Hinge
	27170086	Bottom board

**MECHANISM-COMPONENT LOCATION**

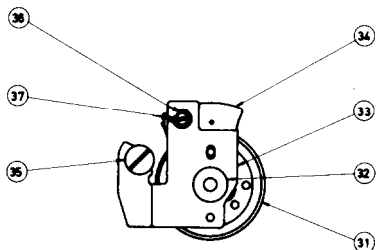
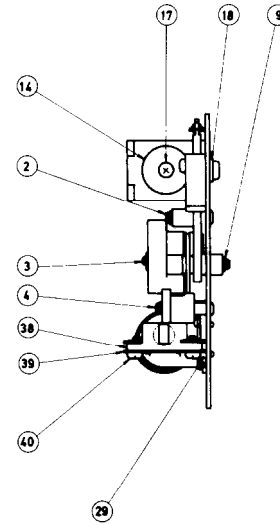
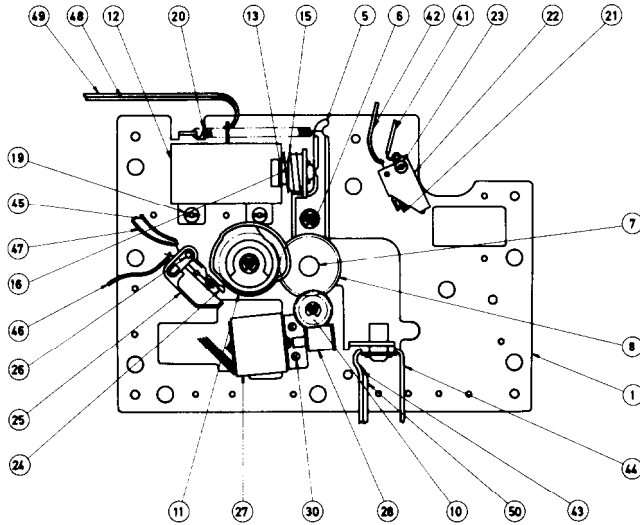

**REF. NO. PARTS NO. DESCRIPTION**

1	24506452	Chassis	24	24503102	Switch
2		Shaft	25	24506463	Cover
3		Shaft	26	82112022	Screw
4		Shaft	27, 28	24502113	Motor ass'y
5	24504304	Lever	29	24506464	Rubber plate
6	893020	E-2, Circlip	30	82152006	Machine screw
7, 8	24503104	Gear ass'y	31-34	24502106	Pulley ass'y
9	893030	E-3, Circlip	32		Bush
10	24503097	Gear	33		Plate
11	24503098	Cam gear	34		Shutter
12-18	24506474	Solenoid ass'y	35	24506468	Eccentric pin
19	24506470	Screw	36	24506469	Eccentric pin
20	24503100	Spring	37	893030	E-3, Circlip
21	24503101	Switch	38-40	24506142	Interruptor ass'y
22	24506462	Cover	41-50		Lead wire
23		Screw		24506450A	Mechanism ass'y

SCHEMATIC DIAGRAM

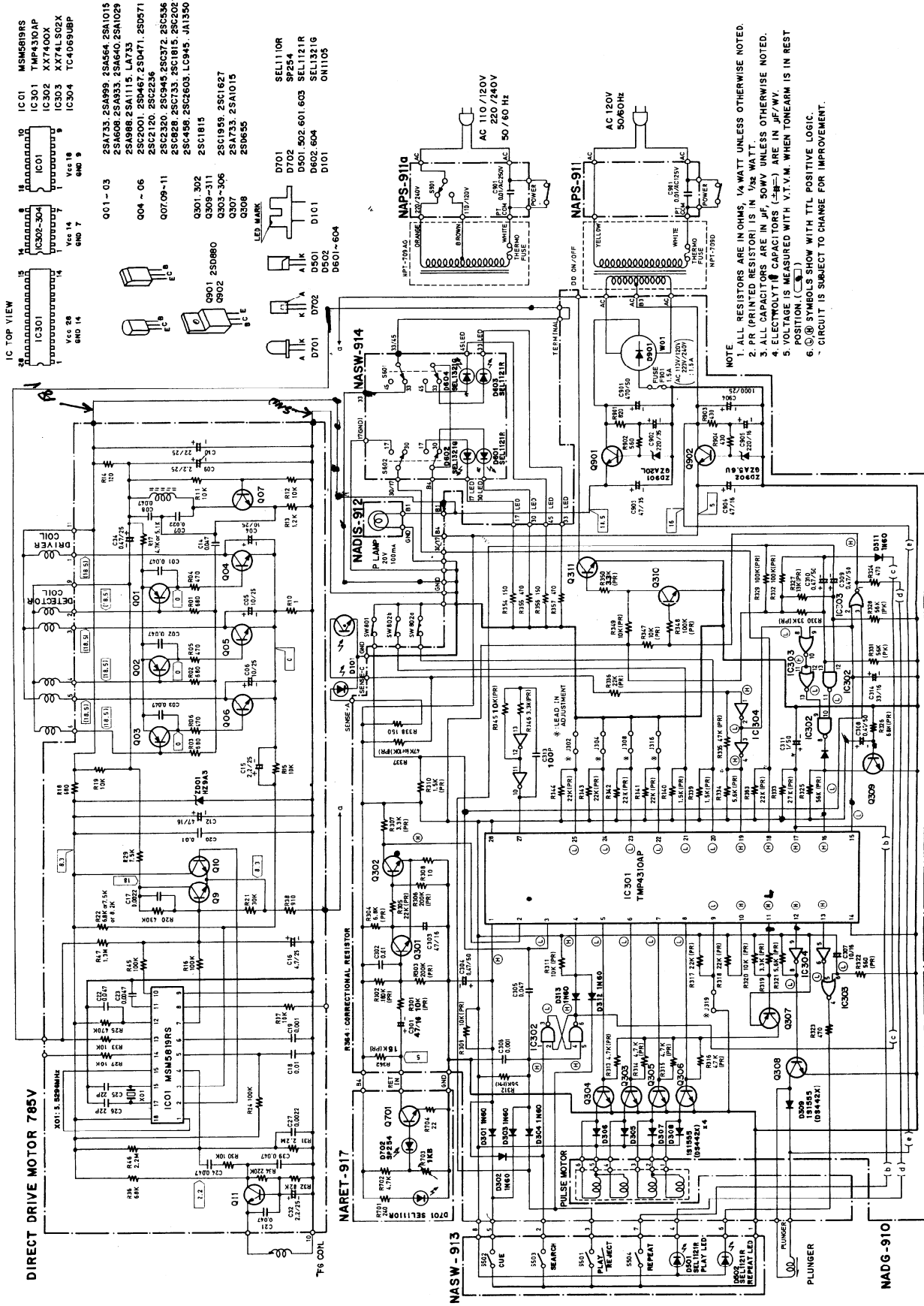

IC TOP VIEW

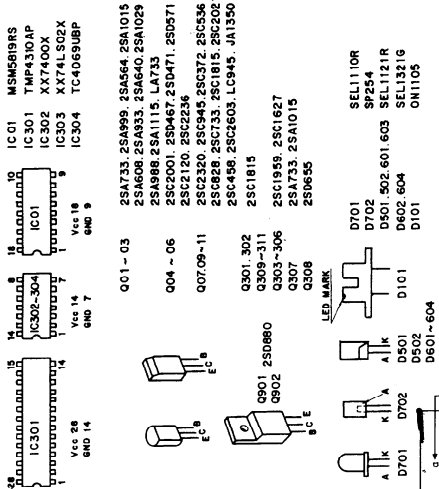

- IC301 MSMS819RS
- IC301 TMP4310AP
- IC302 XX7400X
- IC303 XX74LS02X
- IC304 TC4069UBP
- Q01-Q03 2SA733, 2SA999, 2SA564, 2SA1015, 2SA608, 2SA333, 2SA640, 2SA1029, 2SA988, 2SA1115, LA733, 2SC2001, 2SD467, 2SD471, 2SD571, 2SC120, 2SC2236, 2SC2320, 2SC945, 2SC372, 2SC536, 2SC628, 2SC733, 2SC1815, 2SC2021, 2SC458, 2SC2603, LC945, JA1550, 2SC1815, 2SC1815
- Q04-Q06 2SC1959, 2SC1627, 2SC1959, 2SC1627, 2SA733, 2SA1015, 2SD655
- Q07-Q08-11 2SC1815, 2SC1815, 2SC1815, 2SC1815, 2SC1815, 2SC1815, 2SC1815, 2SC1815, 2SC1815, 2SC1815, 2SC1815
- Q301, 302 2SD680, 2SD680
- Q303-306 2SA733, 2SA1015, 2SD655
- D01 SEL110R
- D02 SEL141R
- D03 SEL131R
- D04 SEL131G
- D05 ON110S
- D06 ON110S
- D07 D701
- D08 D101
- D09 D101
- D10 D101
- D11 D101

NOTE

1. ALL RESISTORS ARE IN OHMS, 1/4 WATT UNLESS OTHERWISE NOTED.
2. PR (PRINTED RESISTOR) IS IN 1/2 WATT.
3. ALL CAPACITORS ARE IN  $\mu$ F, 50MV UNLESS OTHERWISE NOTED.
4. ELECTROLYTIC CAPACITORS (E- $\mu$ F) ARE IN  $\mu$ F/WV.
5. VOLTAGE IS MEASURED WITH V.T.V.M. WHEN TONEARM IS IN REST POSITION. (C-3)
6.  $\odot$  SYMBOLS SHOW WITH TTL POSITIVE LOGIC.
7. CIRCUIT IS SUBJECT TO CHANGE FOR IMPROVEMENT.



## ADJUSTMENT PROCEDURES

### 1. Tonearm height

- 1) Remove the T.T. mat.
- 2) Press the record size selector to 17cm position and the power switch to the ON position.
- 3) Press the play/reject button.
- 4) As soon as the tonearm comes over the turntable platter, press the power switch to the off position.
- 5) Adjust the screw on the lifter plate for  $14 \pm 1$ mm height between the stylus tip and the turntable platter.

Note: To adjust the height for lower, turn the screw clockwise. To adjust the height for higher, turn the screw counter-clockwise.

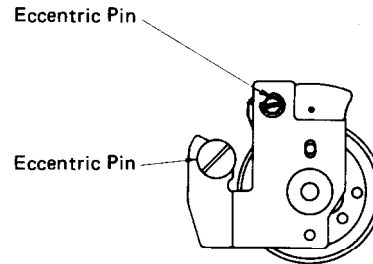

### 2. Auto-return position

Adjust the return position by the large eccentric pin attached by the tonearm base. To adjust the return position for faster, turn the eccentric pin clockwise. To adjust the return position for later, turn the eccentric pin counter-clockwise.

### 3. Lead-in position

Adjust the lead-in position by the small eccentric pin attached by the tonearm base. Press the record size selector to 30cm position and the speed selector to 45 r.p.m.

To adjust lead-in position for faster (outside), turn the eccentric pin clockwise. To adjust the lead-in position for later (inside), turn the eccentric pin counter-clockwise.

Press the record size selector to 17cm position and confirm the lead-in position. When outside the lead-in position, connect or cut the jumper wires by referring to the below table.

	Cut	Connect
J319	fast	late
J302	0.4 mm	
J304	0.8 mm	
J308	1.6 mm	
J316	3.2 mm	