



Deze download wordt u gratis aangeboden door Pick-upnaalden.nl

Web : www.pickupnaalden.com
Email : info@pick-upnaalden.nl
Facebook : www.facebook.com/pickupnaalden
Twitter : twitter.com/Pickupnaalden
Google+ : https://plus.google.com/+FCaris_pickupnaalden

ONKYO SERVICE MANUAL

QUARTZ LOCKED DIRECT DRIVE FULLY AUTOMATIC TURNTABLE MODEL CP-1057F

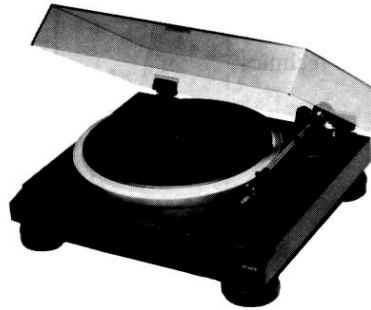

UDN, UDC, UD	120V AC, 60Hz
UGV, UG	220V AC, 50Hz
UW	120 or 220V AC, 50/60Hz
UQA, UQB	240V, 50Hz

SAFETY-RELATED COMPONENT WARNING!!

COMPONENTS IDENTIFIED BY MARK \triangle ON THE SCHEMATIC DIAGRAM AND IN THE PARTS LIST ARE CRITICAL FOR RISK OF FIRE AND ELECTRIC SHOCK. REPLACE THESE COMPONENTS WITH ONKYO PARTS WHOSE PARTS NUMBERS APPEAR AS SHOWN IN THIS MANUAL.

MAKE LEAKAGE-CURRENT OR RESISTANCE MEASUREMENTS TO DETERMINE THAT EXPOSED PARTS ARE ACCEPTABLY INSULATED FROM THE SUPPLY CIRCUIT BEFORE RETURNING THE APPLIANCE TO THE CUSTOMER.

SPECIFICATIONS

Type:	Quartz locked direct drive fully automatic turntable with auto lead-in and return, reject, repeat, cue and search button functions, two-motor micro-computer design
Turntable Platter:	330 mm (13") aluminum die-cast.
Motor:	Quartz locked direct drive brushless DC motor
Speeds:	33-1/3, 45 rpm,
Wow & Flutter:	less than 0.023% (WRMS)
Signal-to-Noise Ratio:	better than 80 dB (DIN B)
Tonearm:	Statically balanced straight type
Effective Arm Length:	226 mm (8-7/8")
Overhang:	15 mm (1/2")
Offset Angle:	21 degrees
Maximum Tracking Error:	+3 degrees, -1 degree
Suitable Cartridge Weight:	Min. 4, Max. 9 grams
Tracking Force:	0 - 3.0 grams
Other Features:	Tracking force direct readout scale Removable headshell Anti-skating device

ONKYO[®]
AUDIO COMPONENTS

Dimensions (WxDxH): 442 x 410 x 160 mm
 (17-7/16" x 16-3/16" x 6-1/8")

Weight: 8.8 kg (20 lbs.)

Accessories: Headshell, counterweight, overhang gauge, adapter, instruction manual

Cartridge (G/W) MC type (OC-64MCE/ audio-technica AT-UL3)

Frequency response 20 . . . 40,000 Hz

Output .5 mV

Compliance 8 X10⁻⁶ cm/dyne

Stylus tip 0.4X0.7 mil elliptical stylus/DN-64STE/audio-technica ATN-UL3

Tracking force 1.7 kg

Optional Recommended Headshell: SH-21E

Specifications are subject to change for further product improvements.

SERVICE PROCEDURES

Insulation resistance measurement

Connect the insulating-resistance tester between the plug of power supply cord and chassis.

Specifications; D model 500 V 3.3±0.33 MΩ
 G/W models 500 V more than 10 MΩ

ADJUSTMENT PROCEDURES

1. Return sensitivity adjustment (fig. 1)

Turn the unit upside-down and, with the DD motor and arm motor connector removed, connect a DC voltmeter between TP and GND. Move the arm to the inside of the platter, put the return sensor in the release position and shut out extraneous light. Starting with the semi-fixed resistor R703 set all the way to the left, begin to rotate the resistor clockwise to the point where the voltage between TP and GND rises 2mV above low (a few hundred mV).

2. Platter height adjustment (fig. 2)

Return the unit to the upright position and rotate the float base height adjustment screw. Adjust so that the platter height is 24mm ± 3mm above the cabinet.

3. Stylus height adjustment (Stylus: UD: OC-39M UG: included (OC-64MCE)

Set the tonearm in the up position and adjust the lifter plate screw so the height of the stylus tip is 8mm ± 1mm above the platter mat.

Note 1: The height should be 10.5 mm ± 1mm measured from the surface of the platter.

Note 2: Rotate the lifter plate screw counterclockwise to lower the stylus height and clockwise to raise the stylus height.

4. Lead-in count adjustment (Tracking force: 2 grams Anti-skating force: 2 grams Speed: 45 rpm)

Using test record ONK-1000, adjust so the lead-in count is 10-20 counts for both 30cm and 17cm records. Adjust using the PU pulley shutter and NCDG-1683 printed circuit board jumper lead.

The count changes in the following manner as the jumper leads are cut:

Jumper lead A	3 count changes
Jumper lead B	6 count changes
Jumper lead C	12 count changes
Jumper lead ±	cut: - . connect: +

5. Return count adjustment (Speed: 45 rpm)

Using test record ONK-1000, adjust so the 3mm pitch return count is 24-26 counts. Adjust using the PU pulley eccentricity pin. Confirm that the tonearm does not return until 22 counts at a pitch of 1mm.

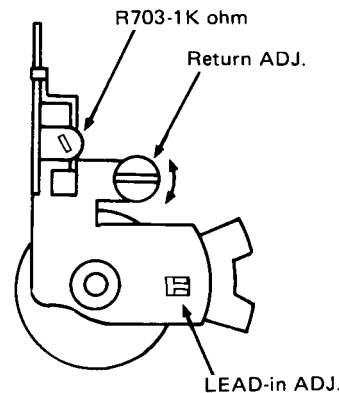

fig. 1

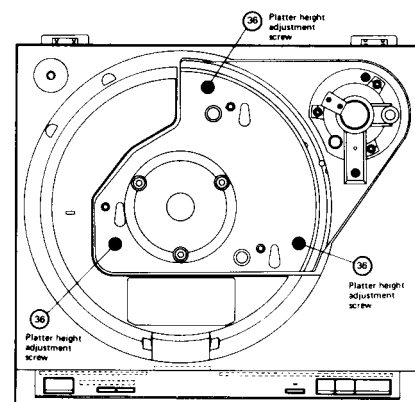
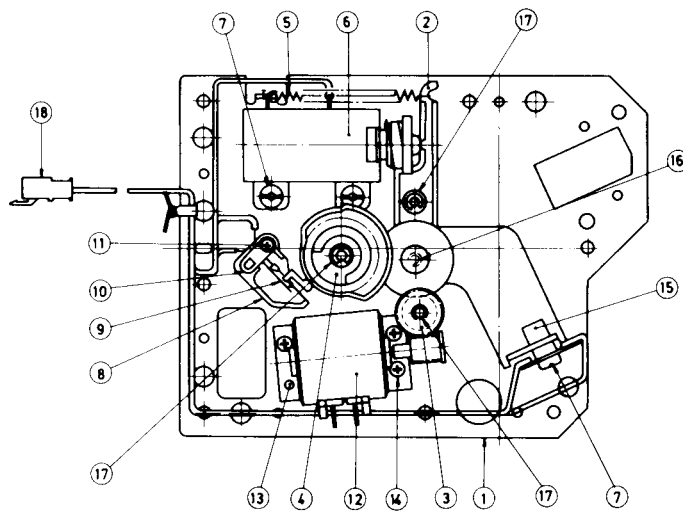

fig. 2

MECHANISM COMPONENT LOCATION



REF. NO.	PARTS NO.	DESCRIPTION
1	24506644-1	Chassis
2	24504310-1	Lever
3	24503097	Wheel
4	24503098	Cam wheel
5	24503139	Tension spring
6	2000448	Solenoid
7	24506437	Screw
8	24506463	Cover
9	24503102	Switch
10	24509234	Spacer
11	82112024	2P-24FN, Pan head screw
12	24502125B	Motor ass'y
13	24506464	Rubber plate
14	82142306	2.3P + 6FN (BC), Pan head screw
15	24506596	Photo diode/transistor ass'y
16	893030	E-3, Circlip
17	893020	E-2, Circlip
18	2000448	NSAS-7P407, Socket

MICROCOMPUTER

TMP4315BP(1032)

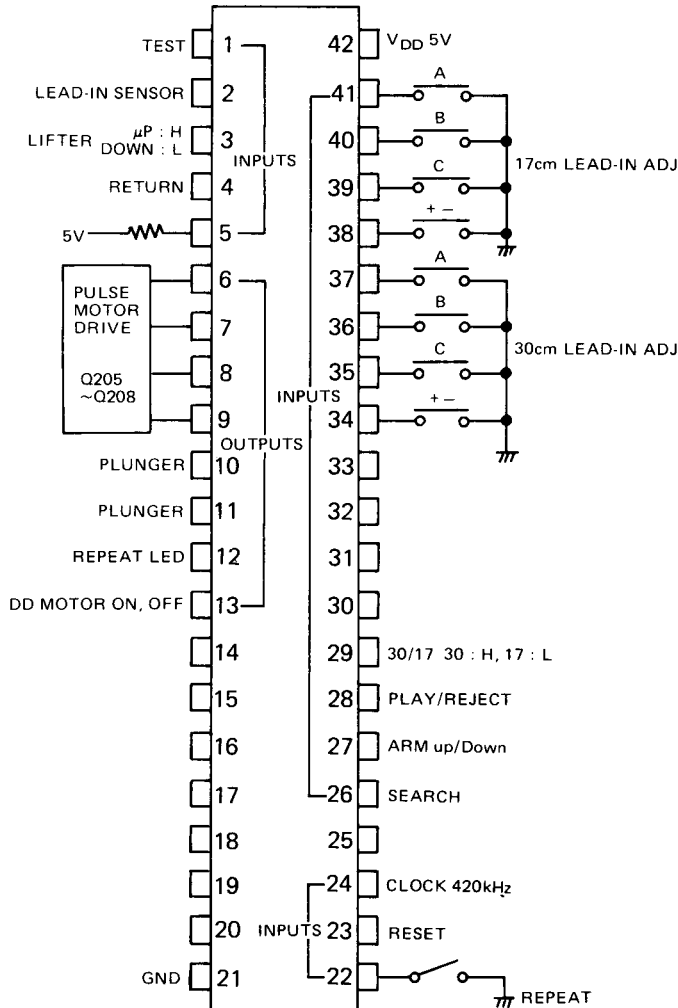

COMPONENT LOCATION PARTS LIST

REF NO.	PARTS NO.	DESCRIPTION	REF NO.	PARTS NO.	DESCRIPTION	
A301	28110299B	Cabinet (D)	M001	24502178	780V2, Motor ass'y	
	28110270-1A	Cabinet (G/W)	P1	253112	AS-UC-4, Power supply cable (D)	
A303	28110331A	Floating base ass'y		253083-1	AS-CEE, Power supply cable (G/W)	
A307	24509333	Dust cover ass'y	P2	270280	SR-4K-4, Strainrelief	
A309	28180077	Hinge ass'y	P3	25050045	NSCT-7P14, Terminal, remote	
A311	27170190-1	Bottom board	P301	24506697	Mechanism ass'y	
A312	24502182	Turntable plate	P302	24501532A	Tone arm ass'y	
A314	27210594	Front panel		24501321A	Screw	
A315	28135109	Baji		24501533	Weight ass'y	
A316	28191306	Clear plate L		24501325	Headshell	
A318	28322122A	Knob, power ass'y		242963A	OC-64MCE, Cartridge ass'y (G/W)	
A320	28140612	Cushion		242964A	DN-64STE, Stylus (G/W)	
A321	28140209	Cushion	P303	24501330	Cartridge attachment parts ass'y	
A325	28322117	Knob(R) ass'y		24501138	2.6x11, Screw	
A325a	27267270	Guide, knob(R)		24501123	2.6x4, Nut	
A325b	28322118	Knob (PLAY)		24500079	Washer	
A325c	28322119	Knob (CUE)	△ PT101	230709B	NPT-811D, Power transformer (D)	
A325d	28322120	Knob (SEA)		230710	NPT-811G, Power transformer (G)	
A325e	28321164	Knob (REP)		230712	NPT-811ADGQ, Power transformer (W)	
A327	28321156	Knob(L) ass'y		25035385	NPS-111-L349P, Power switch (D)	
A327a	28321164	Knob (REP)	△ SW101	25035386	NPS-111-L350P, Power switch (G/W)	
A329	28191307	Clear plate V		25065168	HXW01310-01-060, Voltage selector switch (W)	
A330	27300598	Mirror		U1	10428544	NADG-2344, Digital circuit pc board ass'y
A331	27190211A	Holder, mirror		U2	10428545	NAPS-2345, Power supply pc board ass'y
A332	27140393	Bracket, AC		U3	10428546	NASWL-2346, Play switch pc board ass'y
A401	24509358	Insulator ass'y (A)	△ SW102	U4	10428547	NASWL-2347, Disc size and speed switches pc board ass'y
A401a	28184284	Leg (1)		U5	10428548	NALED-2348, LED pc board ass'y
A401b	28184285	Leg (2)		U6	10428549	NAPI-2349, Output terminal pc board ass'y (D)
A401c	24509357A	Insulator		U7	10434549A	NAPI-2349a, Output terminal pc board ass'y (G/W)
A401d	28143036	Felto			10428550	NARET-2350, Return detection circuit pc board ass'y
A401e	833430080	3TTP+8P(BC), Tapping screw		Note:	(D): Only 120V model	
A401f	27260182A	Bracket			(G): Only 220V model	
A402	24509355A	Insulator ass'y (B)			(W): Only Universal model	
A402a	27180248A	Spring				
A402b	27140785	Bracket				
A402c	28140624	Cushion				
A403	24509355A	Insulator ass'y (C)				
A403a	27180249A	Spring				
A403b	27140785	Bracket				
A403c	28140623	Cushion				
A404	27270150	Spacer				
A501	28322121	IFC Knob ass'y				
A503	28400012A	IFC cam				
A504	27180234	IFC spring				
A505	870071	WW-6, Wave washer				
A509	24506645A	Arm rest ass'y				
A512	24506648	Lifter plate				
A513	27260112	Lifter shaft				
A514	27180156	Spring				
A515	27180067	Spring				
A516	8930301S	ES-3S, Washer E				
A517	87643010	Washer				
A701	833430080	3TTP+8P(BC), Tapping screw				
A702	831130080	3TTW+8B, Tapping screw				
A703	831430100	3TTW+10P(BC), Tapping screw				
A704	834430108	3TTS+10B(BC), Tapping screw				
A705	834440168	4TTS+16B(BC), Tapping screw				
A706	834440108	4TTB+10B(BC), Tapping screw				
A707	833440200	4TTP+20P(BC), Tapping screw				
A708	801275	Special screw, Power transformer/Insulator				
A709	835140254	4STF+25A, Tapping screw				
A710	86414010	Flange nut				
A711	87644012	W4X12F, Washer				
A712	8761401816	W4X18F, Washer				
A713	27270115	Spacer				

NOTE : THE COMPONENTS IDENTIFIED BY MARK △ ARE CRITICAL FOR LISK OF FIRE AND ELECTRIC SHOCK. REPLACE ONLY WITH PARTS NUMBER SPECIFIED.

COMPONENT LOCATION

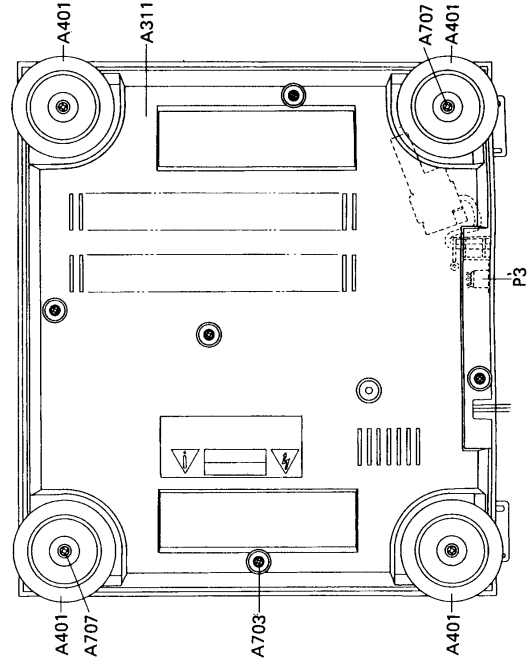
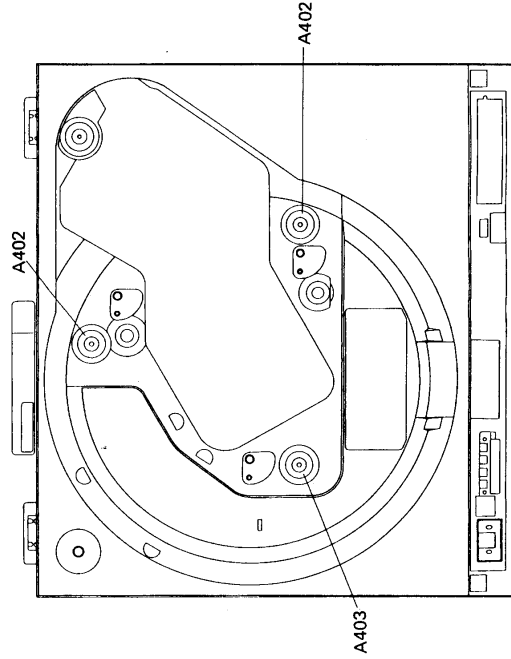
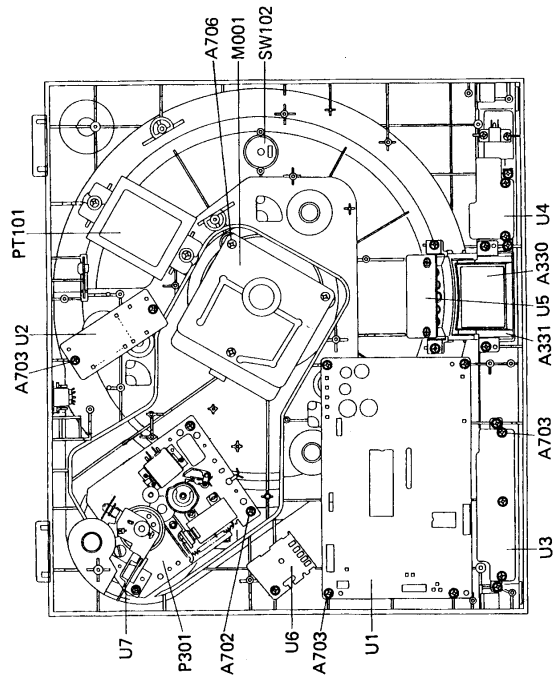
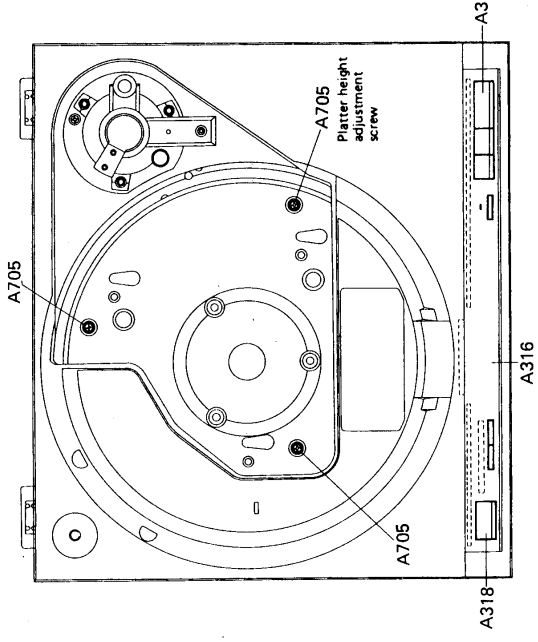
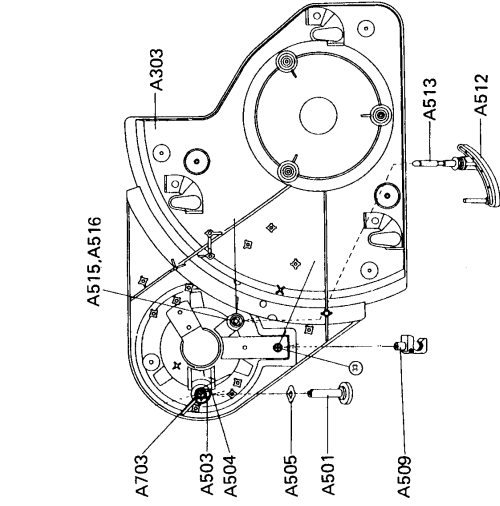
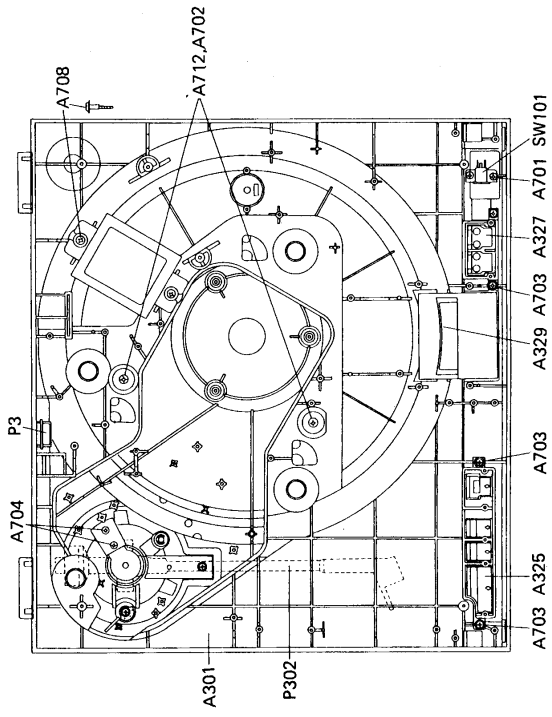

P3

U3

U4

SCHEMATIC DIAGRAM

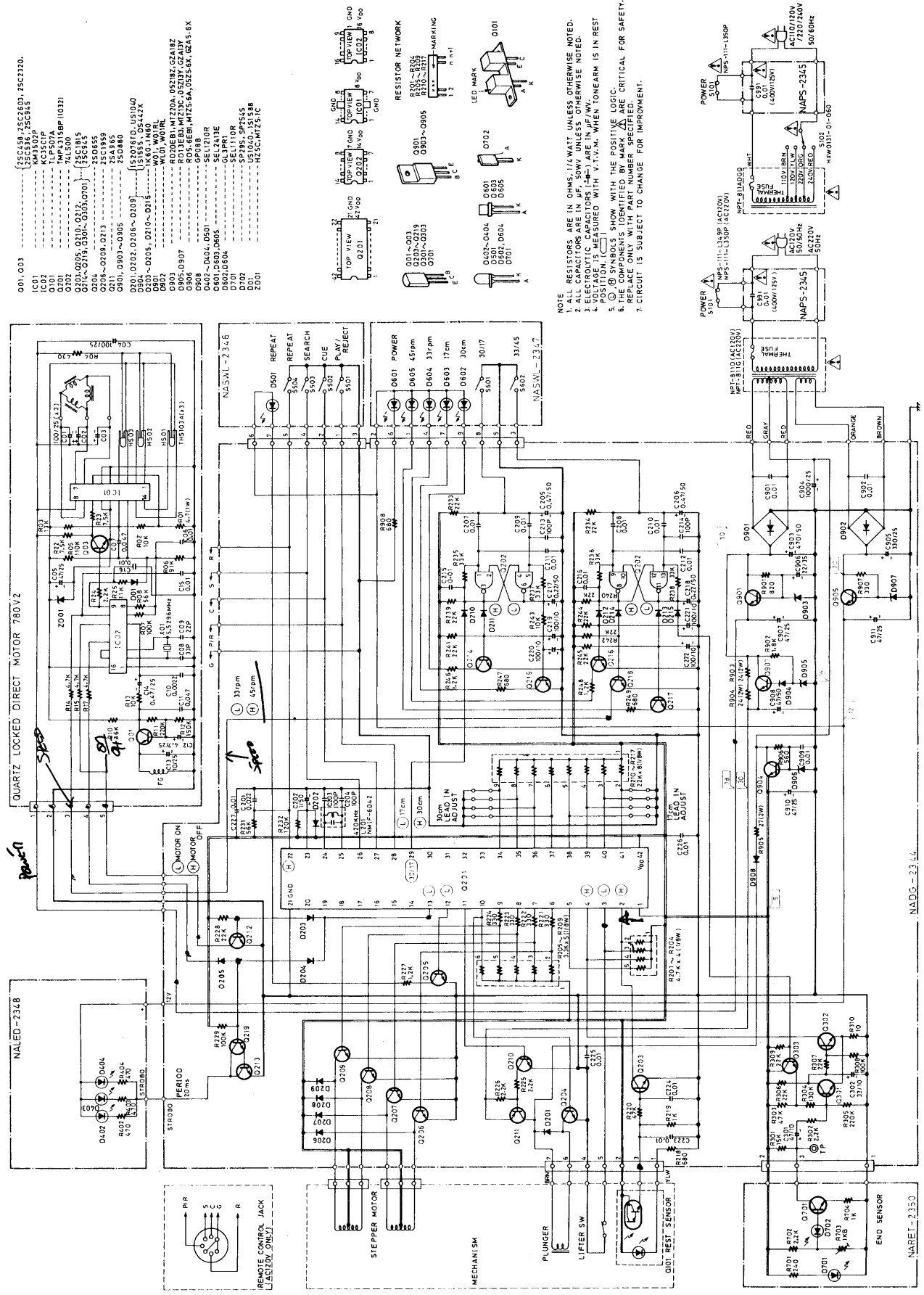

- 001,003 2SC458, 2SC4603, 2SC2320.
- IC01 KM320P, 2SC345
- IC02 KC18C1P
- O101 1AP507A
- O102 74LS00
- O103, O205, O210, O213, O214, O215, O216, O217, O218, O219, O220, O221, O222, O223, O224, O225, O226, O227, O228, O229, O230, O231, O232, O233, O234, O235, O236, O237, O238, O239, O240, O241, O242, O243, O244, O245, O246, O247, O248, O249, O250, O251, O252, O253, O254, O255, O256, O257, O258, O259, O260, O261, O262, O263, O264, O265, O266, O267, O268, O269, O270, O271, O272, O273, O274, O275, O276, O277, O278, O279, O280, O281, O282, O283, O284, O285, O286, O287, O288, O289, O290, O291, O292, O293, O294, O295, O296, O297, O298, O299, O300, O301, O302, O303, O304, O305, O306, O307, O308, O309, O310, O311, O312, O313, O314, O315, O316, O317, O318, O319, O320, O321, O322, O323, O324, O325, O326, O327, O328, O329, O330, O331, O332, O333, O334, O335, O336, O337, O338, O339, O340, O341, O342, O343, O344, O345, O346, O347, O348, O349, O350, O351, O352, O353, O354, O355, O356, O357, O358, O359, O360, O361, O362, O363, O364, O365, O366, O367, O368, O369, O370, O371, O372, O373, O374, O375, O376, O377, O378, O379, O380, O381, O382, O383, O384, O385, O386, O387, O388, O389, O390, O391, O392, O393, O394, O395, O396, O397, O398, O399, O400, O401, O402, O403, O404, O405, O406, O407, O408, O409, O410, O411, O412, O413, O414, O415, O416, O417, O418, O419, O420, O421, O422, O423, O424, O425, O426, O427, O428, O429, O430, O431, O432, O433, O434, O435, O436, O437, O438, O439, O440, O441, O442, O443, O444, O445, O446, O447, O448, O449, O450, O451, O452, O453, O454, O455, O456, O457, O458, O459, O460, O461, O462, O463, O464, O465, O466, O467, O468, O469, O470, O471, O472, O473, O474, O475, O476, O477, O478, O479, O480, O481, O482, O483, O484, O485, O486, O487, O488, O489, O490, O491, O492, O493, O494, O495, O496, O497, O498, O499, O500, O501, O502, O503, O504, O505, O506, O507, O508, O509, O510, O511, O512, O513, O514, O515, O516, O517, O518, O519, O520, O521, O522, O523, O524, O525, O526, O527, O528, O529, O530, O531, O532, O533, O534, O535, O536, O537, O538, O539, O540, O541, O542, O543, O544, O545, O546, O547, O548, O549, O550, O551, O552, O553, O554, O555, O556, O557, O558, O559, O560, O561, O562, O563, O564, O565, O566, O567, O568, O569, O570, O571, O572, O573, O574, O575, O576, O577, O578, O579, O580, O581, O582, O583, O584, O585, O586, O587, O588, O589, O590, O591, O592, O593, O594, O595, O596, O597, O598, O599, O600, O601, O602, O603, O604, O605, O606, O607, O608, O609, O610, O611, O612, O613, O614, O615, O616, O617, O618, O619, O620, O621, O622, O623, O624, O625, O626, O627, O628, O629, O630, O631, O632, O633, O634, O635, O636, O637, O638, O639, O640, O641, O642, O643, O644, O645, O646, O647, O648, O649, O650, O651, O652, O653, O654, O655, O656, O657, O658, O659, O660, O661, O662, O663, O664, O665, O666, O667, O668, O669, O670, O671, O672, O673, O674, O675, O676, O677, O678, O679, O680, O681, O682, O683, O684, O685, O686, O687, O688, O689, O690, O691, O692, O693, O694, O695, O696, O697, O698, O699, O700, O701, O702, O703, O704, O705, O706, O707, O708, O709, O710, O711, O712, O713, O714, O715, O716, O717, O718, O719, O720, O721, O722, O723, O724, O725, O726, O727, O728, O729, O730, O731, O732, O733, O734, O735, O736, O737, O738, O739, O740, O741, O742, O743, O744, O745, O746, O747, O748, O749, O750, O751, O752, O753, O754, O755, O756, O757, O758, O759, O760, O761, O762, O763, O764, O765, O766, O767, O768, O769, O770, O771, O772, O773, O774, O775, O776, O777, O778, O779, O780, O781, O782, O783, O784, O785, O786, O787, O788, O789, O790, O791, O792, O793, O794, O795, O796, O797, O798, O799, O800, O801, O802, O803, O804, O805, O806, O807, O808, O809, O810, O811, O812, O813, O814, O815, O816, O817, O818, O819, O820, O821, O822, O823, O824, O825, O826, O827, O828, O829, O830, O831, O832, O833, O834, O835, O836, O837, O838, O839, O840, O841, O842, O843, O844, O845, O846, O847, O848, O849, O850, O851, O852, O853, O854, O855, O856, O857, O858, O859, O860, O861, O862, O863, O864, O865, O866, O867, O868, O869, O870, O871, O872, O873, O874, O875, O876, O877, O878, O879, O880, O881, O882, O883, O884, O885, O886, O887, O888, O889, O890, O891, O892, O893, O894, O895, O896, O897, O898, O899, O900, O901, O902, O903, O904, O905, O906, O907, O908, O909, O910, O911, O912, O913, O914, O915, O916, O917, O918, O919, O920, O921, O922, O923, O924, O925, O926, O927, O928, O929, O930, O931, O932, O933, O934, O935, O936, O937, O938, O939, O940, O941, O942, O943, O944, O945, O946, O947, O948, O949, O950, O951, O952, O953, O954, O955, O956, O957, O958, O959, O960, O961, O962, O963, O964, O965, O966, O967, O968, O969, O970, O971, O972, O973, O974, O975, O976, O977, O978, O979, O980, O981, O982, O983, O984, O985, O986, O987, O988, O989, O990, O991, O992, O993, O994, O995, O996, O997, O998, O999, O1000.

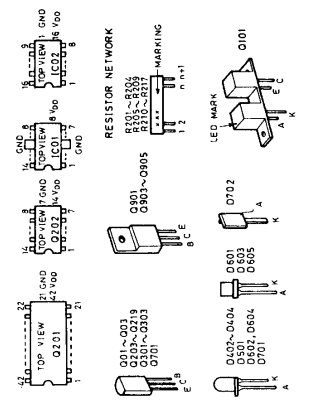

- NOTE
- 1. ALL RESISTORS ARE IN OHMS, 1/4 WATT UNLESS OTHERWISE NOTED.
- 2. ALL CAPACITORS ARE IN PF, 50V UNLESS OTHERWISE NOTED.
- 3. ELECTROLYTIC CAPACITORS L-1, L-2 ARE IN MF/WV.
- 4. POSITIVE LOGIC IS ASSUMED WITH V.I.V.M. WHEN TONEARM IS IN REST.
- 5. ⊕ ⊙ SYMBOLS SHOW WITH THE POSITIVE LOGIC.
- 6. THE COMPONENTS IDENTIFIED BY MARK ⊕ ARE CRITICAL FOR SAFETY.
- 7. CIRCUIT IS SUBJECT TO CHANGE FOR IMPROVEMENT.

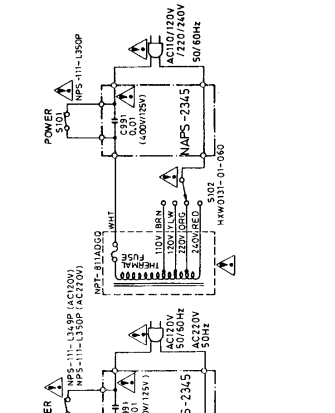

PRINTED CIRCUIT BOARD PARTS LIST

DIGITAL CIRCUIT PC BOARD (NADG-2344)

CIRCUIT NO.	PARTS NO.	DESCRIPTION
	ICs	
A Q201	222773	TMP4315BP(1032)
Q202	222740001	74LS00
	Transistors	
Q203, Q205	2211253,	2SC1815 (O),
Q210, Q212	2211254,	2CS1815 (Y),
Q214-Q219	2211255,	2SC1815 (GR),
	2210746,	2SC945A (P),
	2210747 or	2SC945A (Q) or
	2210748	2SC945A (K)
Q204	2211706	2SC655 (F)
Q206-Q209	2211544	2SC1959 (Y)
Q211	2211644	2SA965 (Y)
Q213	2211544	2SC1959 (Y)
Q301-Q303	2211254 or	2SC1815 (Y) or
	2211255	2SC1815 (GR)
E Q901	2201074	2SD880 (Y)
Q903-Q905	2201074	2SC880 (Y)
	Diodes	
D201, D202	223145,	1S2076TD,
D206-D209	223150,	US1040,
D904	223105 or	1S1555 or
	223133	DS442X
D203-D205	223103 or	1N60 or
D210-D215	223132	1K60
D901	223869 or	W01 or
	223890	W01RL
D902	223862 or	W101 or
	223890	W01RL
C D903	224200,	05Z18Z,
	2241193,	GZA18Z,
	2243281 or	MTZ20A or
	2239731	RD20EB1
D904	223145,	1S2076TD,
	223105,	1S1555,
	223150 or	US1040 or
	223133	DS442X
D905, D907	224190,	05Z13Y,
	2243243,	MTZ13C,
	2241132 or	GZA13Y or
	2239653	RD13EB3
D906	224162,	05Z5.6X,
	2243151,	MTZ5.6A,
	2240951 or	GZA5.6X or
	2239471	RD5.3EB1
D908	223848	GP08B
	Transformer	
L201	232108	NMIF-6042
	Capacitors	
C302	352780109	1 μ F, 50V, Elect.
C205, C206	352784799	0.47 μ F, 50V, Elect.
C217, C218	352782299	0.22 μ F, 50V, Elect.
C219, C222	352731019	100 μ F, 10V, Elect.
C301	352734709	47 μ F, 10V, Elect.
C302	352733309	33 μ F, 10V, Elect.
C903	352784719	470 μ F, 50V, Elect.
C904	352751029	1,000 μ F, 25V, Elect.
C905	352753319	330 μ F, 50V, Elect.
C906	352762209	22 μ F, 50V, Elect.
C907	352754709	47 μ F, 10V, Elect.
C908	352784709	47 μ F, 50V, Elect.
C910, C911	352754709	47 μ F, 10V, Elect.
	Resistors	
R201-R204	49121472504	4.7k Ω , 1/8W, Network
R205-R209	49121332505	3.3k Ω , 1/8W, Network

CIRCUIT NO.	PARTS NO.	DESCRIPTION
R210-R217	49121223508	22k Ω , 1/8W, Network
R903, R904	441722404	24 Ω , 2W, Metal oxide film
R905	441722704	27 Ω , 2W, Metal oxide film
	Sockets	
P204	2000239	NSAS-5P177, DD motor
P205	2000236	NSAS-3P147, Pulse motor
P206	2000237	NSAS-3P175, Pulse motor
	Plugs	
P208	25055042	NPLG-3P32, Return
P209, P210	25055066	NPLG-7P52, Play, Mechanism
P211	25055067	NPLG-9P53, Tape speed
	Radiator	
	27160029	RAD-07

POWER SUPPLY PC BOARD (NAPS-2345)

CIRCUIT NO.	PARTS NO.	DESCRIPTION
C991	3500065A	0.01 μ F, AC400V/125V, Capacitor IS

PLAY SWITCH PC BOARD (NASWL-2346)

CIRCUIT NO.	PARTS NO.	DESCRIPTION
D501	225116 or 225117	SEL1210R (B) or SEL1210R (C), LED
SW501	25035291	NPS-111-S257, Push switches
P502	2000240	NSAS-7P178, Socket

DISK SIZE AND SPEED SWITCHES PC BOARD (NASWL-2347)

CIRCUIT NO.	PARTS NO.	DESCRIPTION
D601, D603	225137	SEL2413E, LEDs
D605		
D602, D604	225126	GL-3PR1, LEDs
SW601	25035291	NPS-111-S257, Push switches
P602	2000242	NASA-9P180, Socket
	28140489	Cushion
	27190213	Holder S

LED PC BOARD (NALED-2348)

CIRCUIT NO.	PARTS NO.	DESCRIPTION
D402, D404	225116 or 225117	SEL1210R (B) or SEL1210R (C), LEDs
	27190212	Holder V

OUTPUT TERMINAL PC BOARD (NAPI-2349)

CIRCUIT NO.	PARTS NO.	DESCRIPTION
P802	24505154	Output cable
	24505157A	Output cable (G/W)

RETURN DETECTION CIRCUIT PC BOARD (NARET-2350)

CIRCUIT NO.	PARTS NO.	DESCRIPTION
Q701	2211254 or 2211255	2SC1815 (Y) or 2SC1815 (GR), Transistor
D701	225053 or 225054	SEL1110R (B) or SEL1110R (C), LEDs
D702	225055	Photo diode ass'y
D703	5215051	NO8HR1KBF, Semi-fixed resistor
P702	2000449	NASA-3P408, Socket
P703	27141003	Bracket L

PACKING VIEW

4STF+25A Tapping screw (835140254)
Spacer (27270115)

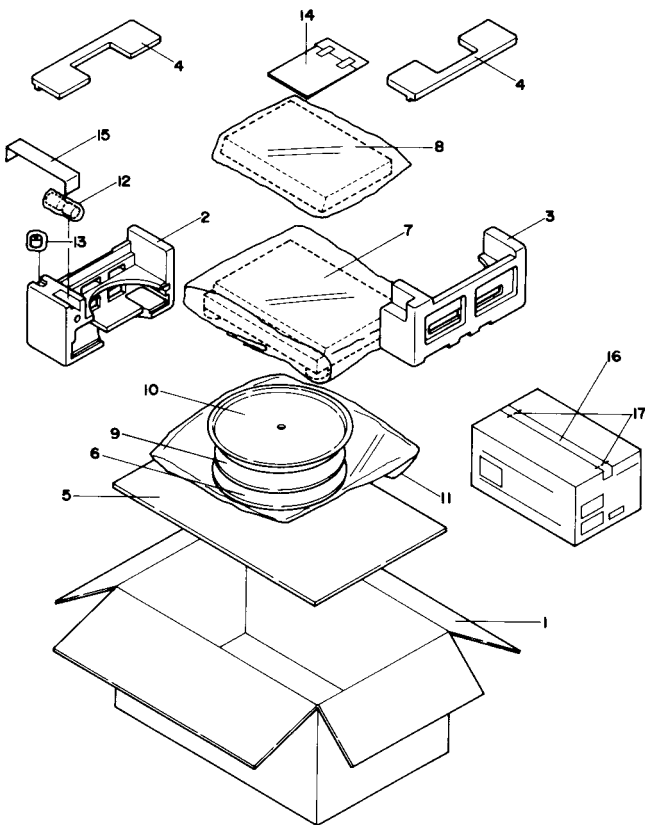
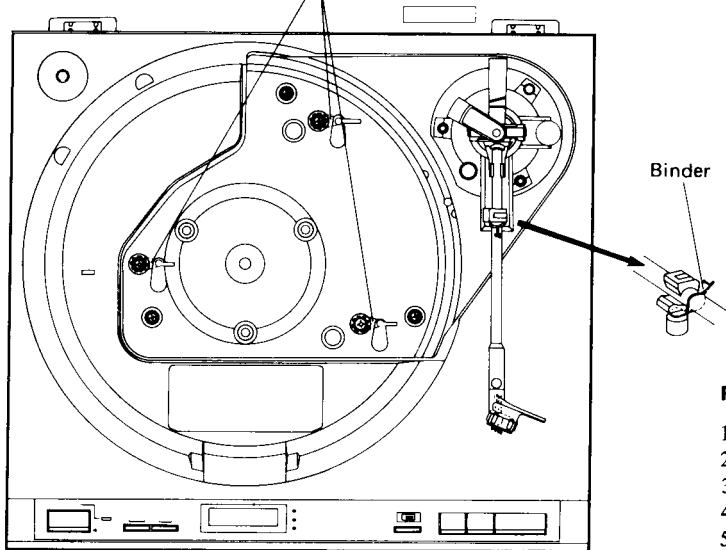

REF.NO.	PART NO.	DESCRIPTION
1	29051133	Master carton box
2	29090993A	Pad (L)
3	29090994A	Pad (R)
4	29090995	Pad (U)
5	29090787	Pad Sheet
6	29095391	Pad Sheet
7	29095152-1	1500 x 600, Protection Sheet
8	24509333	Dust cover
9	24509359	T.T Sheet
10	24502182	Turntable platter
11	29100046	370 x 470, Poly bag
12	28180077	Hinge
13	24501533	Main weight
	29100072	80 x 150, Poly bag
14	Accessory bag complete	
	120V model	
	29340891	Instruction manual
	24509347	Overhang gauge
	29365006-7	Warranty card (Only USA model)
	29358002C	Service station list (Only USA model)
	292049A	45rpm Adaptor
	24501330	Cartridge attachment parts ass'y
	29100006A	250 x 350 Poly bag
	220V model	
	29340892	Instruction manual
	24509347	Overhang gauge
	29365016	Warranty card (Only West Germany model)
	292049A	45rpm Adaptor
	29100006A	250 x 350 Poly bag
	Universal model	
	29340892	Instruction manual
	24509347	Overhang gauge
	25055040	CVK-2, Conversion plug
	292049A	45rpm Adaptor
	29100006A	250 x 350 Poly bag
15	29110051	W60mm P.P tape
16	260012	Damplon tape
17	282301	Sealing hook

ONKYO CORPORATION

International Division: No. 24 Mori Bldg., 23-5, 3-chome, Nishi-Shinbashi, Minato-ku, Tokyo, Japan
Telex: 2423551 ONKYO J. Phone: 03-432-6981

ONKYO U.S.A. CORPORATION

200 Williams Drive, Ramsey, N.J. 07446 Tel. 201-825-7950

ONKYO DEUTSCHLAND GMBH, ELECTRONICS

8034 München-Germering, Industriestrasse 20, West Germany. Telex: 521726 Telefon: (089)-84-9320