



Deze download wordt u gratis aangeboden door Pick-upnaalden.nl

Web : www.pickupnaalden.com
Email : info@pick-upnaalden.nl
Facebook : www.facebook.com/pickupnaalden
Twitter : twitter.com/Pickupnaalden
Google+ : https://plus.google.com/+FCaris_pickupnaalden

ONKYO SERVICE MANUAL

QUARTZ LOCKED DIRECT DRIVE FULLY AUTOMATIC TURNTABLE MODEL CP-1055F



UDN, UDC, UD	120V AC, 60Hz
UGV, UG	220V AC, 50Hz
UW	120 or 220V AC, 50/60Hz
UQA, UQB	240V, 50Hz

SAFETY-RELATED COMPONENT WARNING!!

COMPONENTS IDENTIFIED BY MARK  ON THE SCHEMATIC DIAGRAM AND IN THE PARTS LIST ARE CRITICAL FOR RISK OF FIRE AND ELECTRIC SHOCK. REPLACE THESE COMPONENTS WITH ONKYO PARTS WHOSE PARTS NUMBERS APPEAR AS SHOWN IN THIS MANUAL.

MAKE LEAKAGE-CURRENT OR RESISTANCE MEASUREMENTS TO DETERMINE THAT EXPOSED PARTS ARE ACCEPTABLY INSULATED FROM THE SUPPLY CIRCUIT BEFORE RETURNING THE APPLIANCE TO THE CUSTOMER.

SPECIFICATIONS

Type:	Quartz locked direct drive fully automatic turntable with auto lead-in and return, reject, repeat, cue and search button functions, two-motor micro-computer design
Turntable Platter:	330 mm (13") aluminum die-cast.
Motor:	Quartz locked direct drive brushless DC motor
Speeds:	33-1/3, 45 rpm,
Wow & Flutter:	less than 0.023% (WRMS)
Signal-to-Noise Ratio:	better than 78 dB (DIN B)
Tonearm:	Statically balanced straight type
Effective Arm Length:	224 mm (8-7/8")
Overhang:	13 mm (1/2")
Offset Angle:	21 degrees
Maximum Tracking Error:	+3 degrees, -1 degree
Suitable Cartridge Weight:	Min. 5, Max. 9 grams
Tracking Force:	0 - 3.0 grams
Other Features:	Tracking force direct readout scale Removable headshell Anti-skating device

ONKYO[®]
AUDIO COMPONENTS

Dimensions (WxDxH): 442 x 410 x 155 mm
 (17-7/16" x 16-3/16" x 6-1/8")
 Weight: 8.8 kg (20 lbs.)
 Accessories: Headshell, counterweight,
 overhang gauge, adapter,
 instruction manual

Optional Recommended Headshell: SH-21E

Specifications are subject to change for further product improvements.

SERVICE PROCEDURES

Insulation resistance measurement

Connect the insulating-resistance tester between the plug of power supply cord and chassis.

Specifications; D model 500 V 3.3±0.33 MΩ
 G/W models 500 V more than 10 MΩ

ADJUSTMENT PROCEDURES

1. Return sensitivity adjustment (fig. 1)

Turn the unit upside-down and, with the DD motor and arm motor connector removed, connect a DC voltmeter between TP and GND. Move the arm to the inside of the platter, put the return sensor in the release position and shut out extraneous light. Starting with the semi-fixed resistor R703 set all the way to the left, begin to rotate the resistor clockwise to the point where the voltage between TP and GND rises 2mV above low (a few hundred mV).

2. Platter height adjustment (fig. 2)

Return the unit to the upright position and rotate the float base height adjustment screw. Adjust so that the platter height is 24mm ± 3mm above the cabinet.

3. Stylus height adjustment (Stylus: UD: OC-39M UG: included (OC-60VMS))

Set the tonearm in the up position and adjust the lifter plate screw so the height of the stylus tip is 8mm ± 1mm above the platter mat.

Note 1: The height should be 12mm ± 1mm measured from the surface of the platter.

Note 2: Rotate the lifter plate screw counterclockwise to lower the stylus height and clockwise to raise the stylus height.

4. Lead-in count adjustment (Tracking force: 2 grams Anti-skating force: 2 grams Speed: 45 rpm)

Using test record ONK-1000, adjust so the lead-in count is 10-20 counts for both 30cm and 17cm records. Adjust using the PU pulley shutter and NCDG-1683 printed circuit board jumper lead.

The count changes in the following manner as the jumper leads are cut:

Jumper lead A	3 count changes
Jumper lead B	6 count changes
Jumper lead C	12 count changes
Jumper lead ±	cut: - . connect: +

5. Return count adjustment (Speed: 45 rpm)

Using test record ONK-1000, adjust so the 3mm pitch return count is 24-26 counts. Adjust using the PU pulley eccentricity pin. Confirm that the tonearm does not return until 22 counts at a pitch of 1mm.

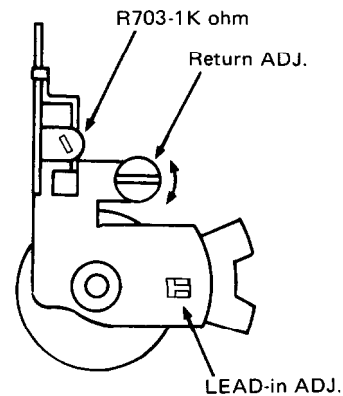

fig. 1

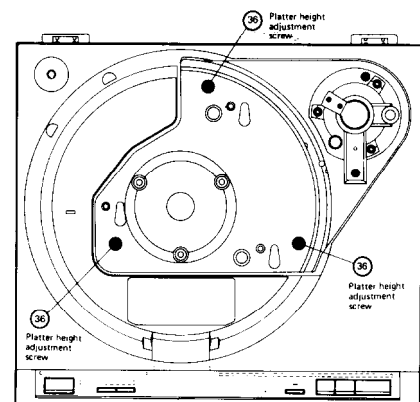
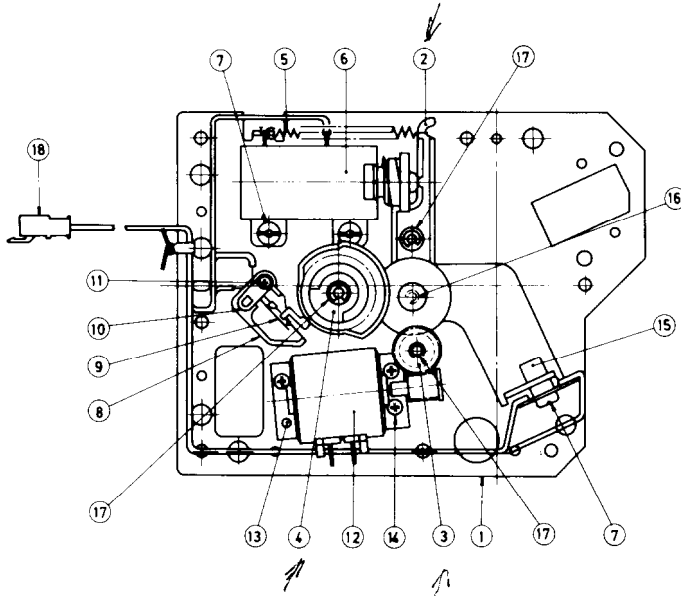

fig. 2

MECHANISM COMPONENT LOCATION



REF. NO.	PARTS NO.	DESCRIPTION
1	24506644	Chassis
2	24504310	Lever
3	24503097	Wheel
4	24503098	Cam wheel
5	24503100	Tension spring
6	24506474	Solenoid
7	24506437	Screw
8	24506463	Cover
9	24503102	Switch
10	24509234	Spacer
11	82112024	2P-24FN, Pan head screw
12	24502125B	Motor ass'y
13	24506464	Rubber plate
14	82142306	2.3P + 6FN (BC), Pan head screw
15	24506596	Photo diode/transistor ass'y
16	893030	E-3, Circlip
17	893020	E-2, Circlip
18	2000241	NSAS-8P179, Socket
19		Belt
20		Label
21	24506658	Screw
22	24506659	Toothed washer
23	24506461	Rubber ring

MICROCOMPUTER

TMP4315AP (1031)

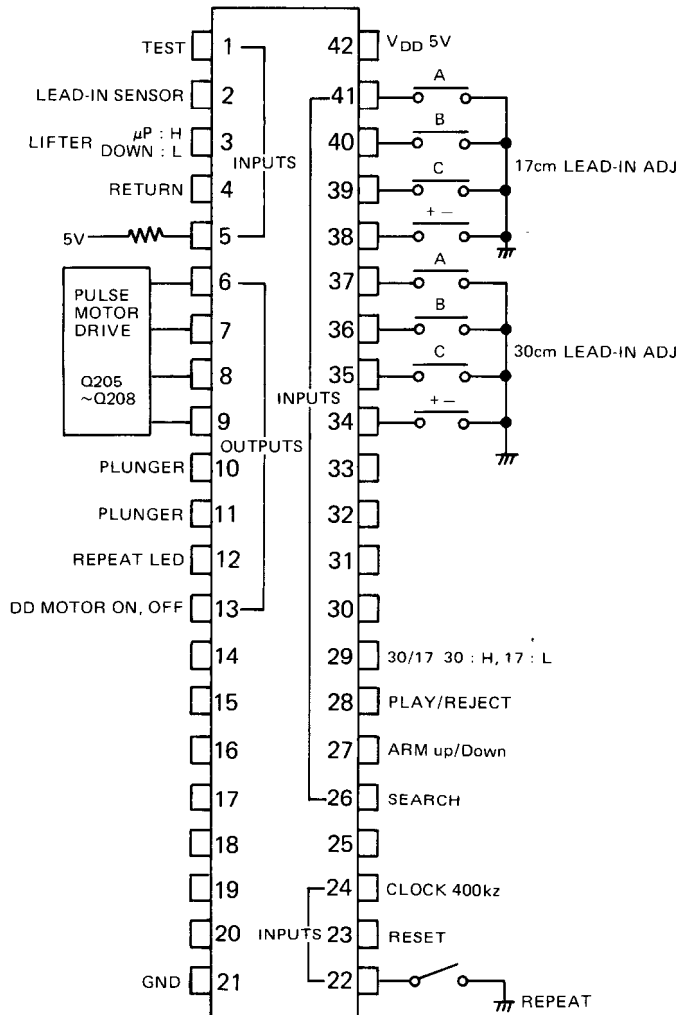

COMPONENT LOCATION PARTS LIST

REF. NO.	PARTS NO.	DESCRIPTION	REF. NO.	PARTS NO.	DESCRIPTION
1	28110268-1	Cabinet	P301	24506642	Mechanism ass'y
2	28110269-1	Floating base ass'y	P302	24501444	Tone arm ass'y (D)
	27260125	Stud		24501146	Tone arm
3	24509280	Dust cover ass'y		24501321-1	Screw
4	28180077	Hinge ass'y		24501147	Weight ass'y
5	27170154	Bottom board		24501448	Counter ring
6	24502157A	Turntable platter		24501449	Main weight
7	27210365-1	Front panel		24501325	Headshell
8	28191190A	Clear plate V	P307	24501330	Cartridge attachment parts ass'y (D)
9	28321155	Knob, power		24501138	Screw
10	27300598	Mirror		24501123	Nut
11	27290211A	Holder, mirror		24500079	Washer
12	28191189B	Clear plate L	P302	24501450	Tone arm ass'y (G/W)
13	27140393	Bracket, AC		24501446	Tone arm
14	27150165	Shield plate		24501321-1	Screw
15	28140209	Cushion		24501147	Weight ass'y
16	28140485	Cushion		24501148	Counter ring
17	27262224	Plate		24501149	Main weight
	28140496	Cushion		24501325	Headshell
18	24509288	Insulator		242951	OC-60VMS, Cartridge ass'y
18-A	24509308			24501441	BD-60VMS, Cartridge
19	24509277	Insulator D		242952	DN-60STE, Stylus
20	24509289	Insulator E		24501443	Stylus cover
21	28321163-1	IFC knob		24501138	2.6x11mm, Screw
22	28400012A	IFC cam		24501123	2.6x4mm, Nut
23	27180175A	IFC spring		24500079	Washer
24	870071	WW-6, Wave washer	△ PT101	230709	NPT-811D, Power transformer (D)
25	24506645A	Arm rest ass'y	△	230710	NPT-811G, Power transformer (G)
26	24506648	Lifter plate	△	230711	NPT-811ADGQ, Power transformer (U)
27	27260112	Lifter shaft	△ SW101	2535385	NPS-111-L349P, Power switch (D)
28	27180156	Spring	△ SW101	25035386	NPS-111-L350P, Power switch (G)
29	27180067	Spring	△ SW102	25065168	HXW0131-01-060, Voltage selector (U)
30	8930301S	ES-3S, Washer E	U1	10128583	NADG-1683, Digital circuit pc board ass'y
31	87643010	W3x10F (BC), Washer	U2	10128584	NAPS-1684, Power supply pc board ass'y
32	833430080	3TTP+8P (BC), Tapping screw	U3	10128585	NASWL-1685, Play switch pc board ass'y
33	831430108	3TTW+10B (BC), Tapping screw	U4	10128586	NASWL-1686, Disl size and speed switches pc board ass'y
34	831130088	3TTW+8B, Tapping screw	U5	10128587	NALED-1687, LED pc board ass'y
35	834430108	3TTS+10B (BC), Tapping screw	U6	10128510B	NAPI-1010b, Output terminal pc board ass'y
36	834440168	4TTS+16B (BC), Tapping screw	U7	10128517B	NARET-917b, Return detection circuit pc board ass'y
37	834440108	4TTS+10B (BC), Tapping screw	U8	10128588A	NADG-1588a, Motor control pc board ass'y (Only used the unit used the motor ass'y of before change.)
39	801275	Special screw, Power transformer/ Insulator	Note:	(D): Only 120V model	
	831130128	3TTS+12B, Tapping screw		(G): Only 220V model	
40	87644012	W4x12F (BC), Washer		Only Universal model	
41	8761401816	W4x18F (BC), Washer			
	27270115	Spacer			
42	87313006	M-3B, Toothed washer			
	835140254	4STF+25A, Tapping screw			
43	28321157	Knob R			
44	28321156	Knob L			
M001	25402154	789V, Motor ass'y (Before change)			
	24502154-1	789V, Motor ass'y (After change)			
		Caution:			
		Remove the motor control pc board of NADG-1588a when replace from the motor ass'y of before change to the motor ass'y of after change. Refer the motor connection diagram of page 8.			
P1	253099A	AS-UC-3, Power supply cable (D)			
P1	253083	AS-CEE, Power supply cable (G/W)			
P2	270025	SR-3P4, Strainrelief (D)			
P2	270280	SR-4K4, Strainrelief (G/U)			
P3	260208	Binder			
P4	25050045	NSCT-7P14, Terminal, remote			

NOTE : THE COMPONENTS IDENTIFIED BY MARK △ ARE CRITICAL FOR LISK OF FIRE AND ELECTRIC SHOCK. REPLACE ONLY WITH PARTS NUMBER SPECIFIED.

COMPONENT LOCATION

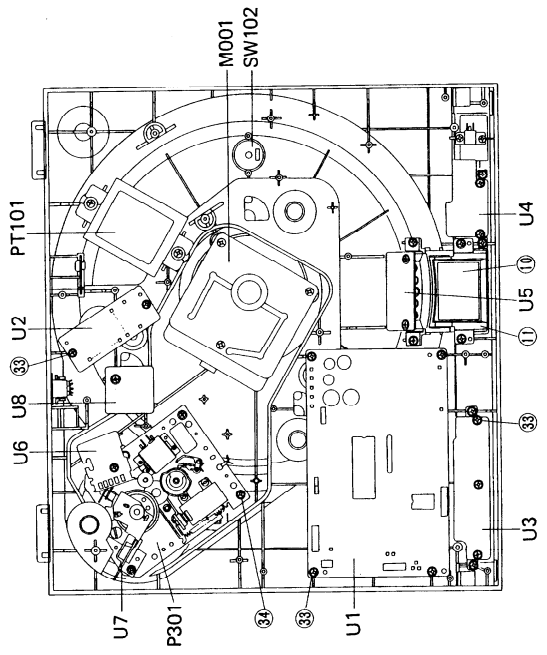
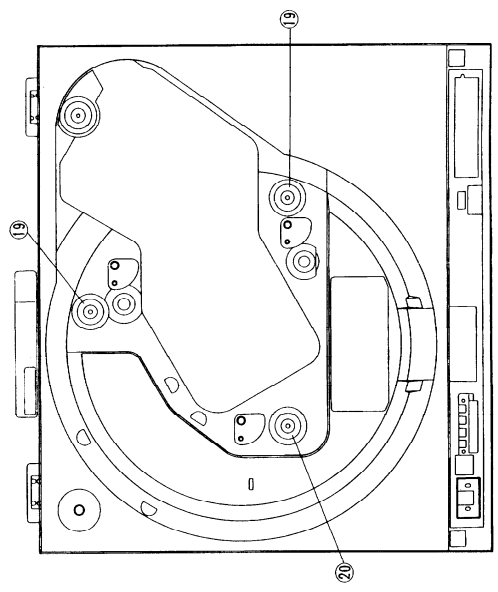
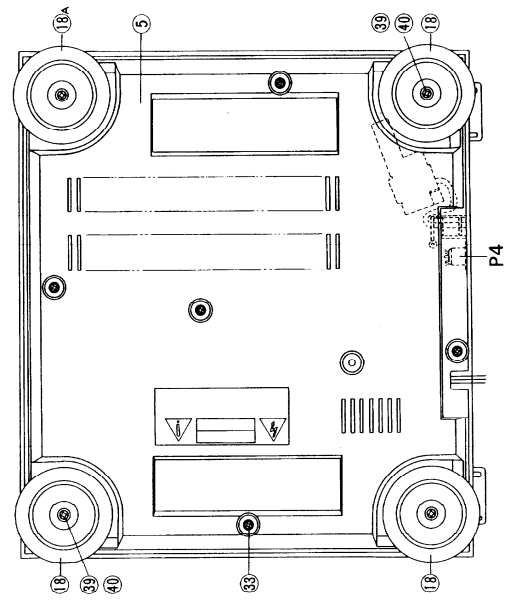
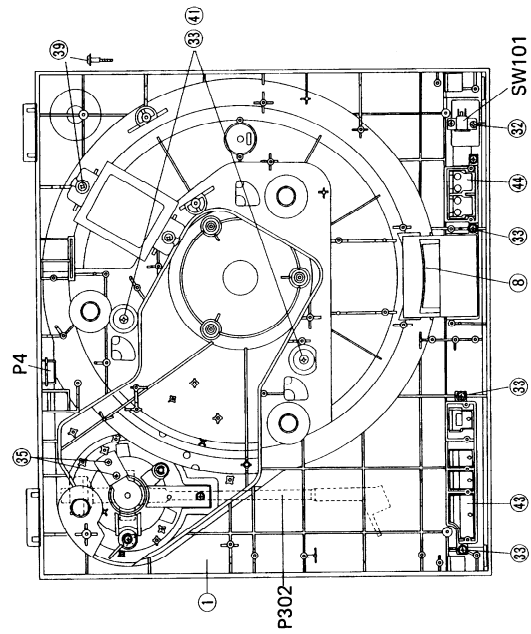
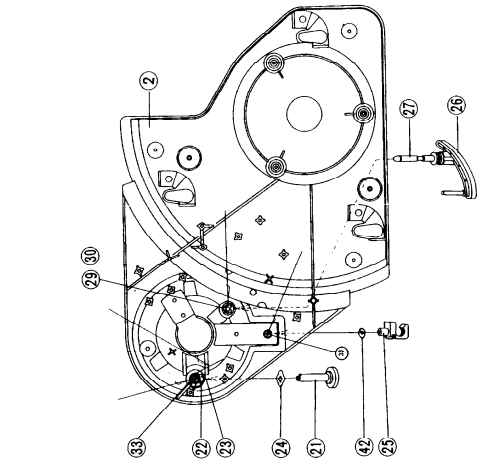
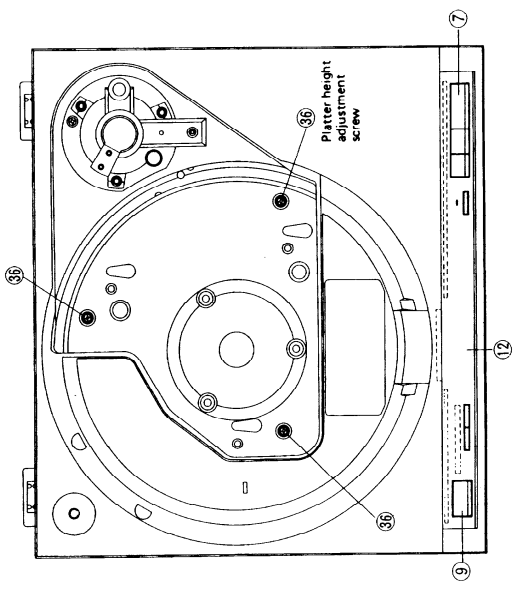

PRINTED CIRCUIT BOARD-PARTS LIST

DIGITAL CIRCUIT PC BOARD (NADG-1683)

CIRCUIT NO.	PARTS NO.	DESCRIPTION
	ICs	
Q201	222677	TMP4315AP (1031)
Q202	222740001	74LS00
	Transistors	
Q203, Q205	2211253,	2SC1815 (O),
Q210, Q212	2211254,	2SC1815 (Y),
Q214-Q219	2211255,	2SC1815 (GR),
	2210746,	2SC945A (P),
	2210747 or	2SC945A (Q) or
	2210748	2SC945A (K)
Q204	2211706	2SC655 (F)
Q206-Q209	2211544	2SC1959 (Y)
Q211	2211644	2SA965 (Y)
Q213	2211544	2SC1959 (Y)
Q301-Q303	2211254 or	2SC1815 (Y) or
	2211255	2SC1815 (GR)
Q901	2201074	2SD880 (Y)
Q902	2211254,	2SC1815 (Y),
	2211255,	2SC1815 (GR),
	2210747 or	2SC945A (Q) or
	2210748	2SC945A (K)
Q903-Q905	2201074	2SC880 (Y)
	Diodes	
D201, D202	223145,	1S2076TD,
D206-D209	223150,	US1040,
D904	223105 or	1S1555 or
	223133	DS442X
D203-D205	223103 or	1N60 or
D210-D215	223132	1K60
△ D901	223869	W01
△ D902	223862	WL01
D903	224200 or	05Z18-Z or
	2241193	GZA18Z
D905, D907	224190 or	D5Z13-Y or
	2241132	GZA13Y
D906	224162 or	05Z5.6X or
	2240951	GZA5.6X
D908	223848	GP08B
	Transformer	
L201	232109	NMIF-6042
	Capacitors	
C202	352780109	1 μ F, 50V, Elect.
C205, C206	352784799	0.47 μ F, 50V, Elect.
C217, C218	352782299	0.22 μ F, 50V, Elect.
C219-C222	352731019	100 μ F, 10V, Elect.
C301	352734709	47 μ F, 10V, Elect.
C302	352733309	33 μ F, 10V, Elect.
C903	352784719	470 μ F, 50V, Elect.
C904	352751029	1,000 μ F, 25V, Elect.
C905	352753319	330 μ F, 25V, Elect.
C907	352754709	47 μ F, 25V, Elect.
C908	352784709	47 μ F, 50V, Elect.
C910, C911	352754709	47 μ F, 25V, Elect.
	Resistors	
R201-R204	49121472504	4.7kohmx4, 1/8W, Network
R205-R209	49121332505	3.3kohmx5, 1/8W, Network
R210-R217	49121223508	22kohmx8, 1/8W, Network
R903-R905	441722704	27ohm, 2W, Metal oxide film
	Sockets	
P204	2000239	NSAS-5P177, DD motor
P205	2000236	NSAS-3P174, Pulse motor
P206	2000237	NSAS-3P175, Pulse motor

CIRCUIT NO.	PARTS NO.	DESCRIPTION
	Plugs	
P208	25055042	NPLG-3P32, Return
P209	25055066	NPLG-7P52, Play
P210	25055051	NPLG-8P39, Mechanism
P211	25055067	NPLG-9P53, Tape speed

Radiator

27160029 RAD-07

POWER SUPPLY PC BOARD (NAPS-1684)

CIRCUIT NO.	PARTS NO.	DESCRIPTION
△ C991	3500065A	0.01 μ -F, AC400V/125V, Capacitor IS

PLAY SWITCH PC BOARD (NASWL-1685)

CIRCUIT NO.	PARTS NO.	DESCRIPTION
D501	225116 or	SEL1210R (B) or
	225117	SEL1210R (C), LED
SW501	25035291	NPS-111-S257, Push switches
P502	2000240	NSAS-7P178, Socket

DISK SIZE AND SPEED SWITCHES PC BOARD (NASWL-1686)

CIRCUIT NO.	PARTS NO.	DESCRIPTION
D601, D603,	225137	SEL2413E, LEDs
D605		
D602, D604	225126	GL-3PR1, LEDs
SW601	25035291	NPS-111-S257, Push switches
P602	2000242	NSAS-9P180, Socket
	28140489	Cushion
	27190213	Holder S

LED PC BOARD (NALED-1687)

CIRCUIT NO.	PARTS NO.	DESCRIPTION
D401-D405	225116 or	SEL1210R (B) or
	225117	SEL1210R (C), LEDs
	27190212	Holder V

OUTPUT TERMINAL PC BOARD (NAPI-1010b)

CIRCUIT NO.	PARTS NO.	DESCRIPTION
P802	24505127	Output cable

RETURN DETECTION CIRCUIT PC BOARD (NARET-917b)

CIRCUIT NO.	PARTS NO.	DESCRIPTION
Q701	2211254 or	2SC1815 (Y) or
	2211255	2SC1815 (GR), Transistor
D701	225053 or	SEL1110R (B) or
	225054	SEL1110R (C), LED
D702	225055	Photo diode ass'y
R703	5215051	NO8HR1KBF, Semi-fixed resistor
P702	2000238	NSAS-3P176, Socket
P703	27140411A	Bracket L

MOTOR CONTROL PC BOARD (NADG-1588a)

CIRCUIT NO.	PARTS NO.	DESCRIPTION
D611-D613	2231333	DS-442X
C631	352780109	1 μ F, 50V, Elect.

PACKING VIEW

4STF+25A Tapping screw (835140254)
Spacer (27270115)

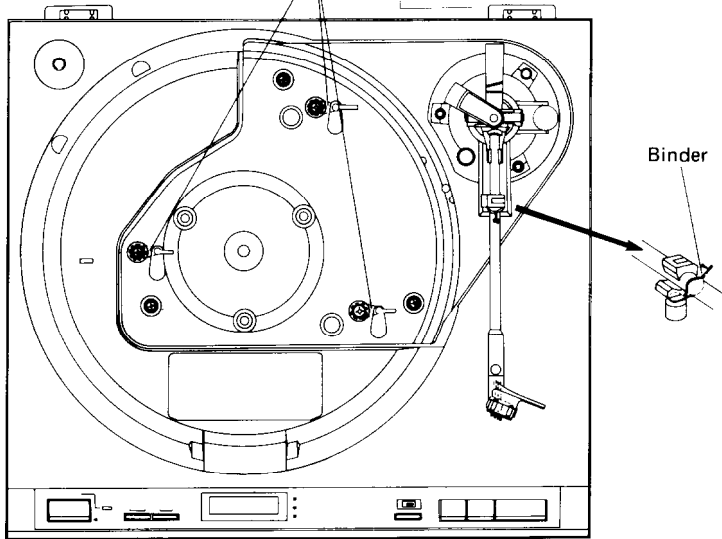

REF. NO.	PARTS NO.	DESCRIPTION
1	29050755	Master carton box
2	29090785A	Pad
3	29090826	Pad, tonearm
4	29090825	Pad L
5	29090787	Pad sheet
6	29100067	750x750mm, Poly-vinyl bag
7	29095295	Sheet
8	24502157A	Turntable platter
	24509183	T.T. sheet
	29100046	370x470mm, Poly-vinyl bag
9	24501449	Counter weight
	29100002A	80x150mm, Poly-vinyl bag
10	260013	P.P tape
11		Accessory bag complete
120V model		
	29340685	Instruction manual
	292049A	45rpm adaptor
	24509197	Overhang gauge
	24501330	Cartridge attachment parts ass'y
	29358002	Service station list (Only USA model)
	29365006-5	Warranty card (Only USA model)
	29100005	220x330mm, Poly-vinyl bag
220V model		
	29340686	Instruction manual
	292049A	45rpm adaptor
	24509197	Overhang gauge
	29358004	Service station list (only West Germany model)
	29365005-3A	Warranty card (Only West Germany model)
	29100005	220x330mm, Poly-vinyl bag

120/220V model

29340686	Instruction manual
292049A	45rpm adaptor
29509197	Overhang gauge
25055040	C-V-K2, Conversion plug
29100005	220x330mm, Poly-vinyl bag
260012	W550mm, Dampson tape
282301	Sealing hook

12
13

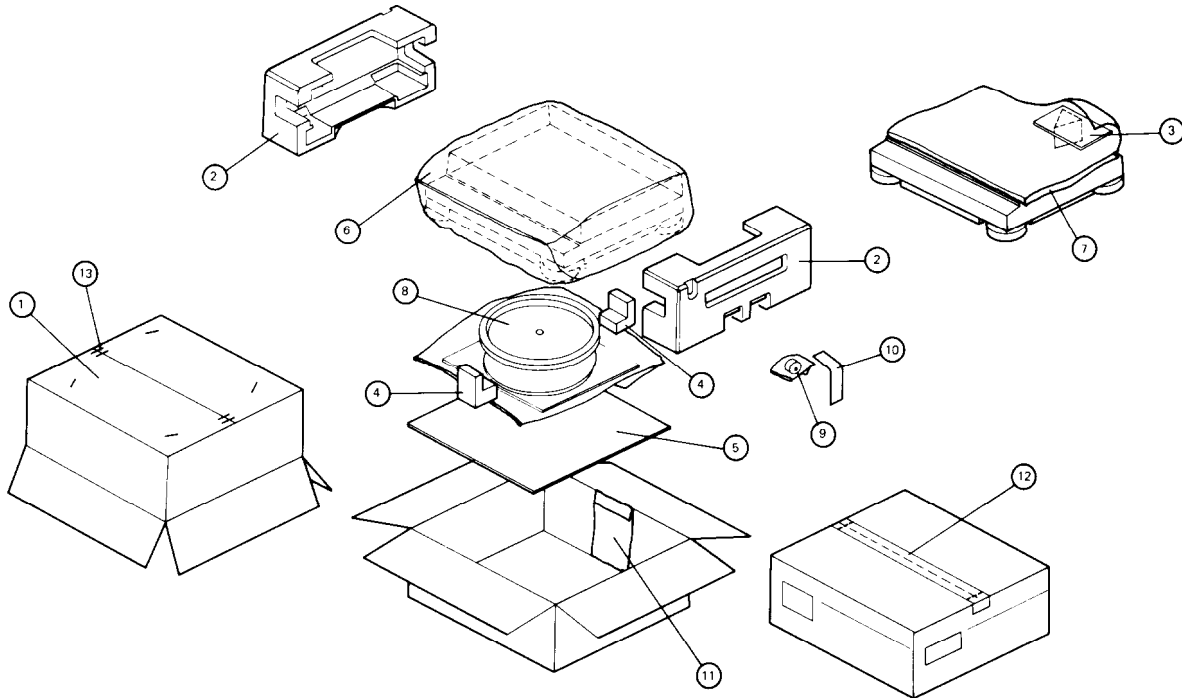

ONKYO CORPORATION

International Division: No. 24 Mori Bldg., 23-5, 3-chome, Nishi-Shinbashi, Minato-ku, Tokyo, Japan
Telex: 2423551 ONKYO J. Phone: 03-432-6981

ONKYO U.S.A. CORPORATION

200 Williams Drive, Ramsey, N.J. 07446 Tel. 201-825-7950

ONKYO DEUTSCHLAND GMBH, ELECTRONICS

8034 München-Germering, Industriestrasse 18, West Germany. Telex: 521726 Telefon: (089)-84-3071

PARTS LIST

MODEL CP-1055F

REF.NO	PART NO.	DESCRIPTION	REF. NO.	PART NO.	DESCRIPTION
1	28110268-1	Cabinet		27270115	Spacer
2	28110269-1	Floating base assy	42	87313006	M-3B,Toothed washer
	28110269-1A	(2501-)			
	27260125	Stud(1-2500)	43	28321157	Knob R
3	24509280	Dust cover ass'y	44	28321156	Knob L
4	28180077	Hinge ass'y	M001	24502154-1A	789V, Motor ass'y
5	27170154	Bottom board	P1	253099B	AS-UC-3, Power supply cord <D>
6	24502157A	Turntable platter		253083-1	AS-CEE, Power supply cord <G>
7	27210365-1	Front panel			
8	28191190A	Clear plate V	P2	270025	SR-3P-4, Strain-relief <D>
9	28321155	Knob, power		270280	SR-4K-4, Strain-relief <G>
10	27300598	Mirror			
11	27190211A	Holder, mirror<E>			
12	28191189B	Clear plate L	P3	260208	Binder
	28191189C	(1001-)	P4	25050045	NSCT-7P14, Terminal remote
13	27140393	Bracket, AC			
14	27150165	Shield plate	P301	24506642	Mechanism ass'y
15	28140209	Cushion	P302	24501445A	Tone arm ass'y <D>
16	28140485	Cushion		24501446A	Tone arm
17	27262224	Plate		24501321A	Special screw
	28140496A	Cushion		24501447A	Weight ass'y
18	24509288A	Insulator L		24501448	Counter ring
18A	24509308A	Insulator L		24501449A	Main weight
19	24509277	Insulator D		24501325	Headshell
20	24509289	Insulator E	P307	24501330	Cartridge attachment parts ass'y <D>
21	28321163-1	IFC knob		24501138	Screw
22	28400012A	IFC cam		24501123	Nut
23	27180234	IFC spring		24500079	Washer
24	870071	WW-6, Wave washer		24501445A	Tone arm ass'y <G>
25	24506645A	Arm rest ass'y		24501446A	Tone arm
26	24506648	Lifter plate	P302	24501321A	Special screw
27	27260112	Lifter shaft		24501447A	Weight ass'y
28	27180156	Spring		24501448	Counter ring
29	27180067	Spring		24501449	Main weight
30	8930301S	ES-3S, Washer E		24501325	Headshell
31	87643010	W3×10F(BC), Washer		242951	OC-60VMS, Cartridge
32	833430080	3TTP+8P(BC), Tapping screw		242952	DN-60STE, Stylus
33	831430100	3TTW+10P(BC), Tapping screw		24501443	Stylus cover
34	831130088	3TTW+8B, Tapping screw		24501138	2.6 ×11, Screw
35	834430108	3TTS+10B(BC), Tapping screw		24501123	2.6 ×4, Nut
36	834440168	4TTS+16B(BC), Tapping screw		24500079	Washer
37	834440108	4TTS+10B(BC), Tapping screw	PT101	230709A	NPT-811D, Power transformer <D>
39	801275	Special screw, Power transformer & Insulator		230710	NPT-811G, Power transformer <G>
40	87644012	W4×12F(BC), Washer	SW101	25035385	NPS-111-L349P, Power switch <D>
41	8761401816	W4×18F(BC), Washer		25035386	NPS-111-L350P, Power switch <G>
			U1	10128583	NADG-1883, Digital circuit pc board ass'y

Page 2

REF.NO.	PART NO.	DESCRIPTION
U2	10128584	NAPS-1684,Power supply pc board ass'y
U3	10128585	NASWL-1685,Play switch pc board ass'y
U4	10128586	NASWL-1686,Disk size and speed switch pc board ass'y
U5	10128587	NALED-1687,LED pc board ass'y
U6	10128510B	NAPI-1010b, Output terminal pc board ass'y
U7	10128517B	NARET-917b,Return detection circuit pc board ass'y

CP-1055F SERVICE INFORMATION

SYMPTOM

ACOUSTIC FEEDBACK (HOWLING)

The acoustic feedback level may be some differences among CP-1055Fs.
If the level is higher than average, check and fix it by this information.

CAUSE

Floating base ass'y is not free from the cabinet and it touches around the right corner nearly the arm shaft.

This symptom can easily confirm by pressing (*) part lightly.

HOW TO FIX

Adjust the height adjustment screws of the platter. (Refer service manual page 2 Fig 2.)

Turning the screw(s) clockwise, the floating base move upward and vice versa.

The screw(s) should be adjusted through the holes of the platter.

PROCEDURE

Adjust the screw(A) turning clockwise one or two turns.

If the floating base is not free yet, adjust the screw(B) and screw(C).

The screw(A) is the most effective to adjust and the screw(B) and screw(C) are less.

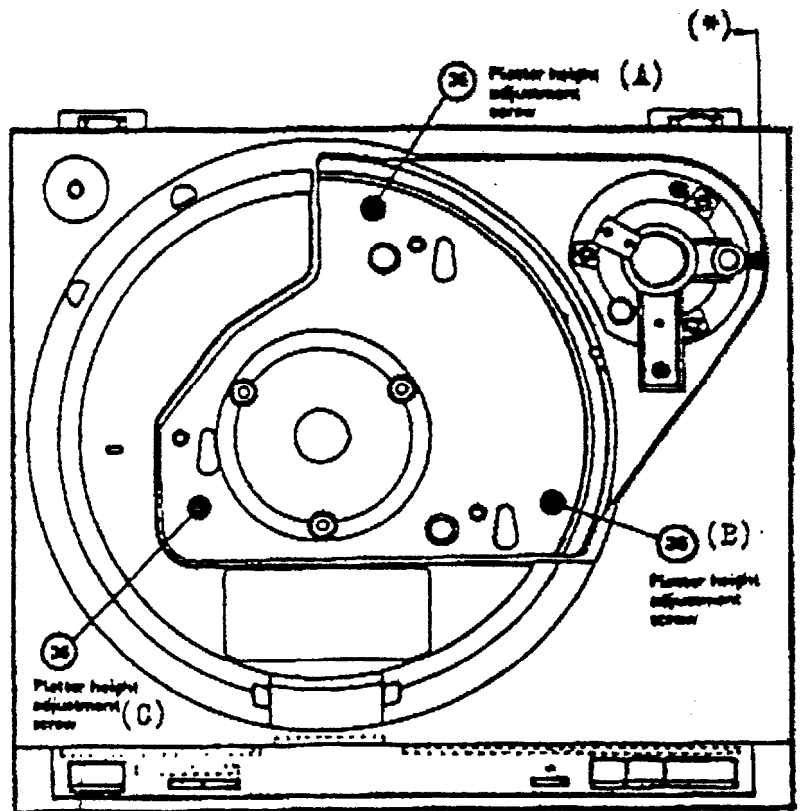

NOTE

These adjustment of the floating base have priority over the height of platter (24 ± 3 mm) described in service manual.

CONFIRMATION

Push the (*) part lightly and check the floating base is free.