



Deze download wordt u gratis aangeboden door Pick-upnaalden.nl

Web : [www.pickupnaalden.com](http://www.pickupnaalden.com)  
Email : [info@pick-upnaalden.nl](mailto:info@pick-upnaalden.nl)  
Facebook : [www.facebook.com/pickupnaalden](http://www.facebook.com/pickupnaalden)  
Twitter : [twitter.com/Pickupnaalden](http://twitter.com/Pickupnaalden)  
Google+ : [https://plus.google.com/+FCaris\\_pickupnaalden](https://plus.google.com/+FCaris_pickupnaalden)

# ONKYO SERVICE MANUAL

SERIAL NO. 3159

## QUARTZ LOCKED DIRECT DRIVE FULLY AUTOMATIC TURNTABLE MODEL CP-1044F



UDN, UD	120V AC, 60 Hz
UU	110/120/220/240V AC, 50/60 Hz

### SAFETY-RELATED COMPONENT WARNING!!

COMPONENTS IDENTIFIED BY MARK  $\triangle$  ON THE SCHEMATIC DIAGRAM AND IN THE PARTS LIST ARE CRITICAL FOR RISK OF FIRE AND ELECTRIC SHOCK. REPLACE THESE COMPONENTS WITH ONKYO PARTS WHOSE PARTS NUMBERS APPEAR AS SHOWN IN THIS MANUAL.

MAKE LEAKAGE-CURRENT OR RESISTANCE MEASUREMENTS TO DETERMINE THAT EXPOSED PARTS ARE ACCEPTABLE INSULATED FROM THE SUPPLY CIRCUIT BEFORE RETURNING THE APPLIANCE TO THE CUSTOMER.

### SPECIFICATIONS

Type:	Quartz locked direct drive fully automatic turntable with auto lead-in and return, reject, repeat, cue and search button functions, two-motor micro-computer design
Turntable Platter:	310 mm (12-1/4") aluminum die-cast.
Motor:	Quartz locked direct drive brushless DC motor
Speeds:	33-1/3, 45 rpm
Wow & Flutter:	less than 0.025% (WRMS)
Signal-to-Noise Ratio:	better than 75dB (DIN B)
Tonearm:	Statically balanced straight type
Effective Arm Length:	224 mm (8-7/8")
Overhang:	13 mm (1/2")
Offset Angle:	21 degrees
Maximum Tracking Error:	+3 degrees, -1.5 degrees
Suitable Cartridge Weight:	Min. 5, Max. 9 grams
Tracking Force:	0 - 3.0 grams
Other Features:	Tracking force direct readout scale Removable headshell Anti-skating device

**ONKYO**  
**AUDIO COMPONENTS**

Dimensions (W x D x H) 418 x 376 x 132 mm  
 (16-1/2" x 14-13/16" x 5-1/5")  
 Weight: 6.0 kg (13.2 lbs.)  
 Accessories: Headshell, counterweight, overhang gauge, adapter, instruction manual

Optional Recommended Headshell: SH-21E

Specifications are subject to change for further product improvements.

## SERVICE PROCEDURES

### Insulation resistance measurement

Connect the insulating-resistance tester between the plug of power supply cord and chassis.

Specifications; D model 500 V 3.3±0.33 MΩ  
 G/W models 500 V more than 10 MΩ

## ADJUSTMENT PROCEDURES

### 1. Return sensitivity adjustment (fig. 1)

Turn the unit upside-down and, with the DD motor and arm motor connector removed, connect a DC voltmeter between TP and GND. Move the arm to the inside of the platter, put the return sensor in the release position and shut out extraneous light. Starting with the semi-fixed resistor R703 set all the way to the left, begin to rotate the resistor clockwise to the point where the voltage between TP and GND rises 2mV above low (a few hundred mV).

### 2. Platter height adjustment (fig. 2)

Return the unit to the upright position and rotate the float base height adjustment screw. Adjust so that the platter height is 13mm ± 2mm above the cabinet.

### 3. Stylus height adjustment

Set the tonearm in the up position and adjust the lifter plate screw so the height of the stylus tip is 8mm ± 1mm above the platter mat.

Note 1: The height should be 11mm ± 2mm measured from the surface of the platter.

Note 2: Rotate the lifter plate screw counterclockwise to lower the stylus height and clockwise to raise the stylus height.

### 4. Lead-in count adjustment (Tracking force: 2 grams Anti-skating force: 2 grams Speed: 45 rpm)

Using test record ONK-1000, adjust so the lead-in count is 10-20 counts for both 30cm and 17cm records. Adjust using the PU pulley shutter and NCDG-1731 printed circuit board jumper lead.

The count changes in the following manner as the jumper leads are cut:

Jumper lead A	3 count changes
Jumper lead B	6 count changes
Jumper lead C	12 count changes
Jumper lead ±	cut: - . connect: +

### 5. Return count adjustment (Speed: 45 rpm)

Using test record ONK-1000, adjust so the 3mm pitch return count is 24-26 counts. Adjust using the PU pulley eccentricity pin. Confirm that the tonearm does not return until 22 counts at a pitch of 1mm.

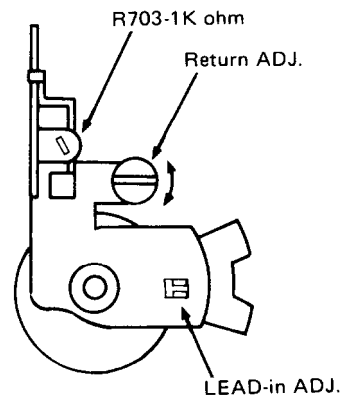

fig. 1

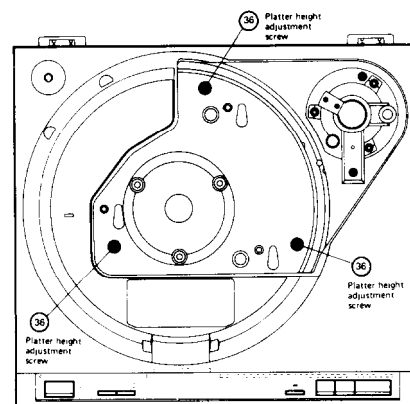
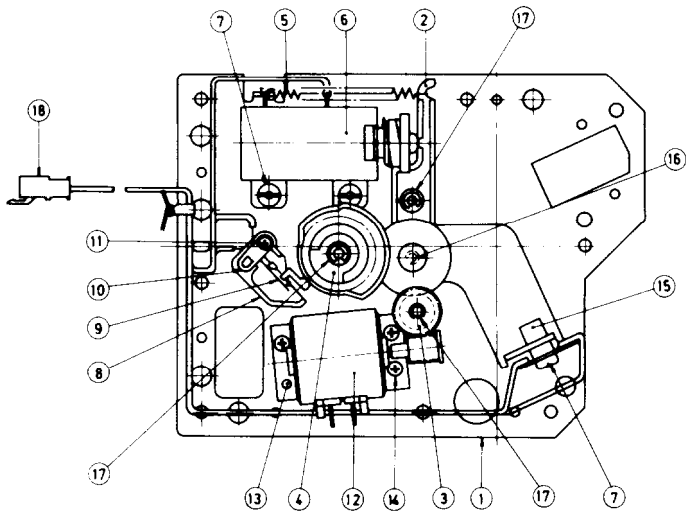

fig. 2

# MECHANISM COMPONENT LOCATION



REF. NO.	PARTS NO.	DESCRIPTION
1	24506644	Chassis
2	24504310	Lever
3	24503097	Wheel
4	24503098	Cam wheel
5	24503100	Tension spring
6	24506474	Solenoid
7	24506437	Screw
8	24506463	Cover
9	24503102	Switch
10	24509234	Spacer
11	82112024	2P-24FN, Pan head screw
12	24502125B	Motor ass'y
13	24506464	Rubber plate
14	82142306	2.3P + 6FN (BC), Pan head screw
15	24506596	Photo diode/transistor ass'y
16	893030	E-3, Circlip
17	893020	E-2, Circlip
18	2000241	NSAS-8P179, Socket
19		Belt
20		Label
21	24506658	Screw
22	24506659	Toothed washer
23	24506461	Rubber ring

# MICROCOMPUTER

TMP4315AP (1031)

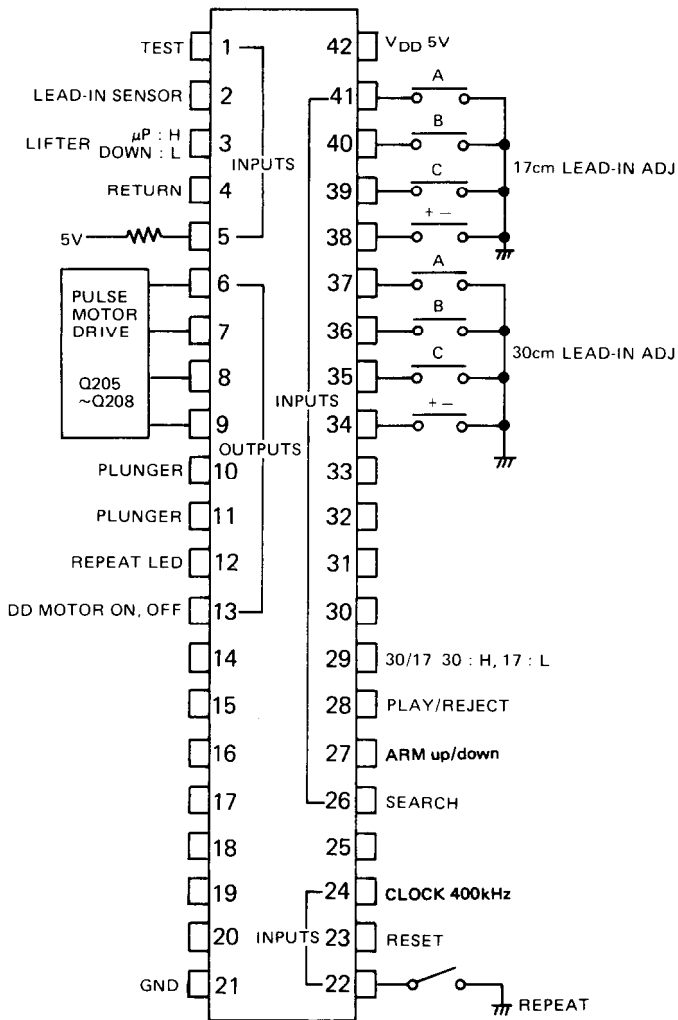

# COMPONENT LOCATION PARTS LIST

REF. NO.	PARTS NO.	DESCRIPTION	REF. NO.	PARTS NO.	DESCRIPTION	
1	28110274	Cabinet	M001	24502155A	787V, Motor ass'y	
4	28110275A	Floating base ass'y	P001	25050045	NSCT-7P14, DIN terminal	
9	24509279	Dust cover	P301	24506642	N35, Fully automatic mechanism ass'y	
11	28180078	Hinge	P302	24501457	Tone arm ass'y	
13	28153076	Bottom board		24501459	Attachment screw	
17	24502159	Turntable platter		24501460	Counter weight	
19	27140866	Bracket B		24501325	Headshell	
20	27140393	Bracket AC	P303	24501330	Attachment part ass'y, cartridge (D)	
22	27150126	Shielded plate		24501138	2.6x11, Screw	
25	27140856	Bracket A		24501123	2.6x4, Nut	
26	28140209	Cushion		24506079	Washer	
27	28140496	Cushion	P304	24501456	Cartridge ass'y (U)	
29	28140507	Cushion		242953	OC-61V, Cartridge	
31	24509313	Insulator G		242954	DN-61ST, Stylus	
32	24509312	Insulator F		24501138	Screw	
33	24509314	Insulator Y		24500079	Washer	
34	24509289	Insulator E		24501123	Nut	
35	28321222	Knob R	P901	253099B	AS-UC-3, Power supply cable (D)	
36	28321221	Knob S		253083	AS-CEE, Power supply cable (U)	
37	28321193	Knob L	P901a	270025	SR-3P-4, Strainrelief (D)	
38	27260119A	Shaft, power		270280	SR-4K-4, Strainrelief (U)	
39	27140749A	Bracket, power	P902	200250	NSAS-5P188, Socket	
40	27260120A	Shaft S	△ PT101	230734	NPT-816D, Power transformer (D)	
42	8930301S	ES-3, Circlip		230735	NPT-816ADGQ, Power transformer (U)	
43	27267289	Guide L	△ SW101	25035385	NPS-111-L349, Power switch (D)	
44	28191196A	Clear plate		25035386	NPS-111-L350P, Power switch (D)	
45	27262234A	Plate 44	△ S002	25065168	HXW0131-01-060, Voltage selector switch (U)	
46	28198596	Facet		U1	10108531	NADG-1731, Power supply and mechanism control pc board ass'y
47	28133078	Back plate A		U2	10128584	NAPS-1684, Power supply terminal pc board ass'y
48	28133079	Back plate B		U3	10108532	NASW-1732, Play switch pc board ass'y
49	28321163-1	Knob IFC		U4	10108533	NALED-1733, Repeat indicator pc board ass'y
50	28400012A	Cam IFC		U5	10101834	NASW-1734, Size/speed indicator pc board ass'y
51	27180175A	Spring IFC		U6	10108535	NALED-1735, Size/speed indicator pc board ass'y
52	27267271	Guide IFC		U7	16627510	NAPI-1010, Output cable terminal pc board ass'y
53	870071	WW-6, Wave washer		U8	10128517B	NARET-917b, Return detection pc board ass'y
54	24506645	Tonearm rest ass'y		Note:	(D): Only 120V model	
55	24506648	Lifter plate			(U): Only Universal model	
56	27260121A	Lifter shaft				
57	27180156	Spring				
58	27180140-1	Spring				
59	8930301S	ES-3S, Circlip				
60	87644012	W4x12, Washer				
61	831430120	3TTW + 12P (BC), Tapping screw				
62	831430100	3TTP + 10P (BC), Tapping screw				
63	834440120	4TTP + 12P (BC), Tapping screw				
64	834440200	4TTP + 20P (BC), Tapping screw				
66	834430108	3TTS + 10B (BC), Tapping screw				
67	82544020	4B + 20FN (BC), Screw				
68	801275	Special screw				
69	82144016	4P + 16FN (BC), Pan head screw				
70	87644012	W4x12F (BC), Washer				
71	8761401816	W4x12F (BC), Washer				
72	27270155	Spacer				
73	87313006	M-3B, Toothed washer				
74	876430100	W3x10F (BC), Washer				
75	27265083	4x5. 3x14, Ring				
76	870060	W3x15, Washer				

**NOTE : THE COMPONENTS IDENTIFIED BY MARK △ ARE CRITICAL FOR LISK OF FIRE AND ELECTRIC SHOCK. REPLACE ONLY WITH PARTS NUMBER SPECIFIED.**

COMPONENT LOCATION

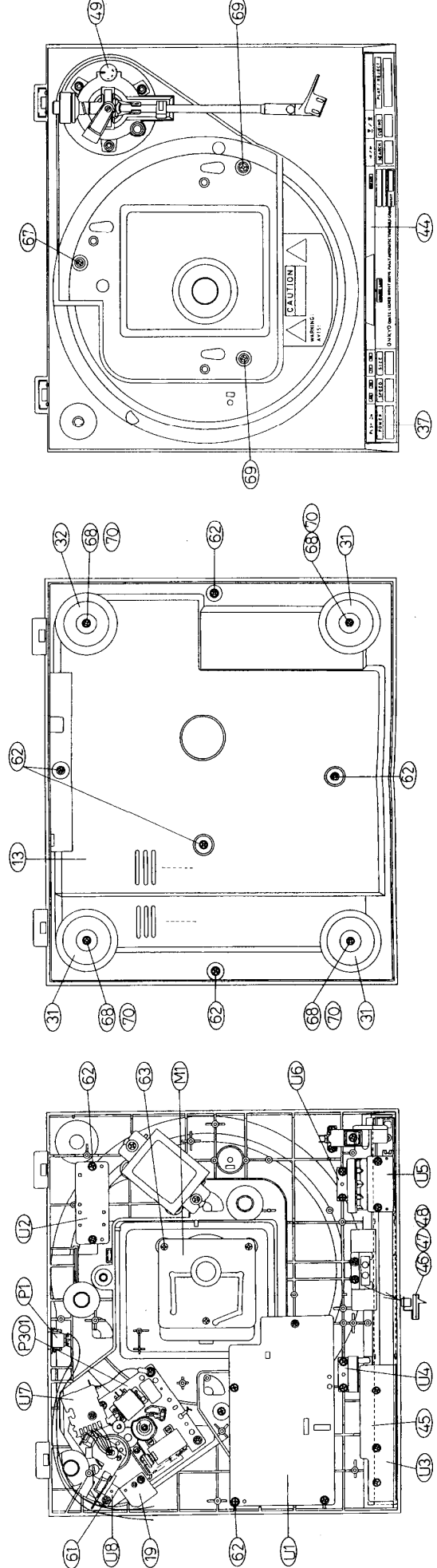
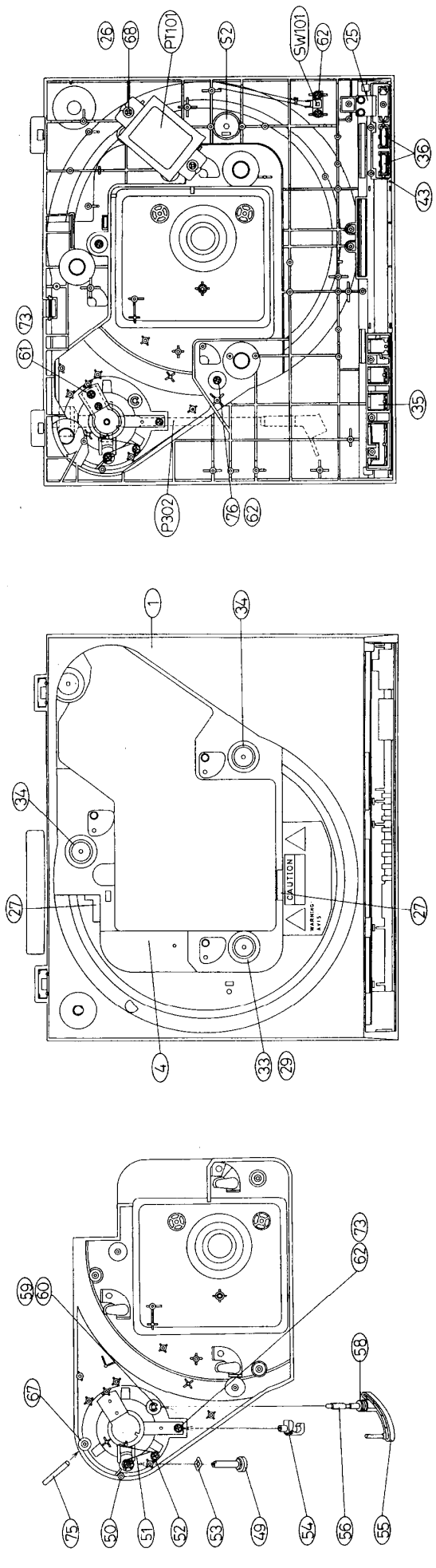



# PRINTED CIRCUIT BOARD-PARTS LIST

## POWER SUPPLY AND MECHANISM CONTROL PC BOARD (NADG-1731)

CIRCUIT NO.	PARTS NO.	DESCRIPTION
Q201	IC 222677	TMP4315AP (1031)
Q203, Q205 Q210, Q212 Q213	Transistors 2211253, 2211254, 2211255, 2210746, 2210747 or 2210748	2SC1815 (O), 2SC1815 (Y), 2SC1815 (GR), 2SC945A (P), 2SC945A (Q) or 2SC945A (K)
Q204	2211706	2SD655 (F)
Q206-Q209	2211544	2SC1959 (Y)
Q211	2211644	2SA965 (Y)
Q301, Q302	2211254 or 2211255	2SC1815 (Y) or 2SC1815 (GR)
Q901, Q903 Q904	2201074 2201074	2SD880 (Y) 2SD880 (Y)
D201, D202 D206, D209 D904	Diodes 223145, 223150, 223105 or 223133	1S2076TD, VS1040, 1S1555 or DS442X
D203, D205	223103 or 223132	1N60 or 1K60
D901	223869	W01
D903	224200 or 2244193	D57Z18-Z or GZA18Z
D905	224190 or 2241132	D5Z13Y or GZA18Z
D906	224162 or 2240951	D5Z5. 6X or GZA5. 6X
D908	223848	GP08B
D907	223929, 2239972 or 2239973	BZ130, RD13FB2 or RD13FB3
L201	Transformer 232108	NMIF-6042
C202	Capacitors 357280109	1 $\mu$ F, 50V, Elect.
C301	352734709	47 $\mu$ F, 10V, Elect.
C302	352733309	33 $\mu$ F, 10V, Elect.
C903	352761029	1,000 $\mu$ F, 35V, Elect.
C904	352751029	1,000 $\mu$ F, 25V, Elect.
C907	352754709	47 $\mu$ F, 25V, Elect.
C908	352764709	47 $\mu$ F, 35V, Elect.
C910	352744709	47 $\mu$ F, 16V, Elect.
C911	352754709	47 $\mu$ F, 25V, Elect.
R201-R204	Resistors 49121472504	4.7kohm $\times$ 4, 1/8W, Network
R205-R209	49121332505	3.3kohm $\times$ 4, 1/8W, Network
R210-R217	49121223508	22kohm $\times$ 8, 1/8W, Network
R903, R904	44172204	22ohm, 1/2W, Metal oxide film
R905	441721804	18ohm, 2W, Metal oxide film
R907	441626804	68ohm, 1W, Metal oxide film
2000239	Sockets 2000239	NSAS-5P177
2000236	2000236	NSAS-3P174
2000237	2000237	NSAS-3P175

## CIRCUIT NO. PARTS NO. DESCRIPTION

CIRCUIT NO.	PARTS NO.	DESCRIPTION
	Plugs	
	25055089	NPLG-3P73
	25055091	NPLG-5P75
	25055093	NPLG-7P77
	55055094	NPLG-8P78

CIRCUIT NO.	PARTS NO.	DESCRIPTION
	Radiators	
	27160029	RAD07
	Lamps	
	210175	14V. 0.06A
	Bracket	
	27140790	

## PLAY SWITCH PC BOARD (NASW-1732)

CIRCUIT NO.	PARTS NO.	DESCRIPTION
	25035291	NPS-111-S257, Push switches
	2000240	NSAS-7P178, Socket

## REPEAT INDICATOR PC BOARD (NALED-1733)

CIRCUIT NO.	PARTS NO.	DESCRIPTION
D501	225142	SEL2913K, LED
	27250062	Lamp case
	27140795	Bracket U
	8334330080	3TTP +8P (BC), Tapping screw

## SIZE/SPEED SWITCH PC BOARD (NASW-1734)

CIRCUIT NO.	PARTS NO.	DESCRIPTION
	25035399	NPS-122-L364, Push switch
	2000249	NSAS-5P178, Socket

## SIZE/SPEED INDICATOR PC BOARD (NALED-1735)

CIRCUIT NO.	PARTS NO.	DESCRIPTION
D601, D603	225142	SEL2913K, LED
D602, D604	225137	SEL2413E, LED
	27250061	Lamp case
	27140795	Bracket U
	833430080	3TTP + 8P (BC), Tapping screw



# PACKING VIEW

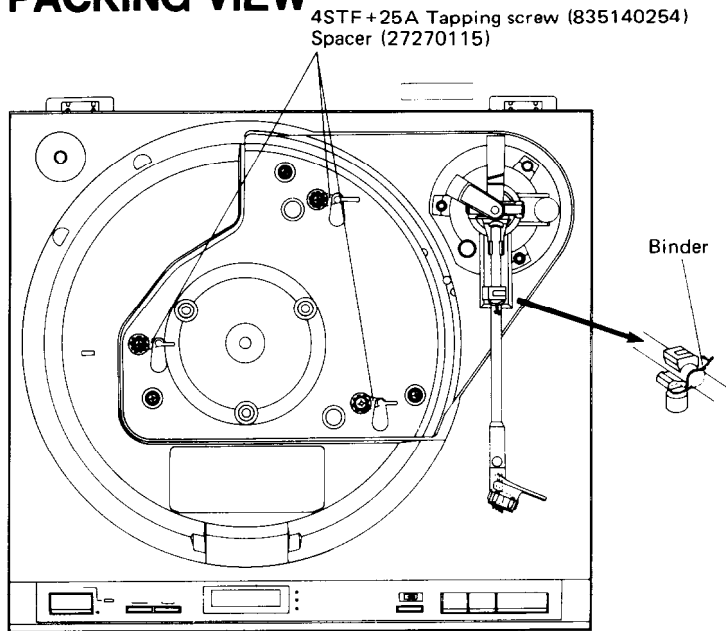

REF. NO.	PARTS NO.	DESCRIPTION
1	29050778	Master carton box
2	29090791	Pad
3	29090837	Pad, tonearm
5	29095286	Pad sheet
6	29100049	640 x 620m/m, Poly-vinyl bag
7	29095295	Sheet
8	24502159	Turntable platter
	24509286	T.T. sheet
	29100046	370x470mm, Poly-vinyl bag
9	24501460	Counter weight
	29100002A	80x150mm, Poly-vinyl bag
10	260013	P.P tape
11		Accessory bag complete
<b>120V model</b>		
	29340704	Instruction manual
	292049A	45rpm adaptor
	24509197	Overhang gauge
	24501330	Cartiridge attachment parts ass'y
	29358002	Service station list (Only USA model)
	29365006-5	Warranty card (Only USA model)
	29100005	220x330mm, Poly-vinyl bag
<b>120/220V model</b>		
	29340705	Instruction manual
	292049A	45rpm adaptor
	29509197	Overhang gauge
	25055040	C-V-K2, Conversion plug
	29100005	220x330mm, Poly-vinyl bag
12	260012	W550mm, Dampilon tape
13	282301	Sealing hook

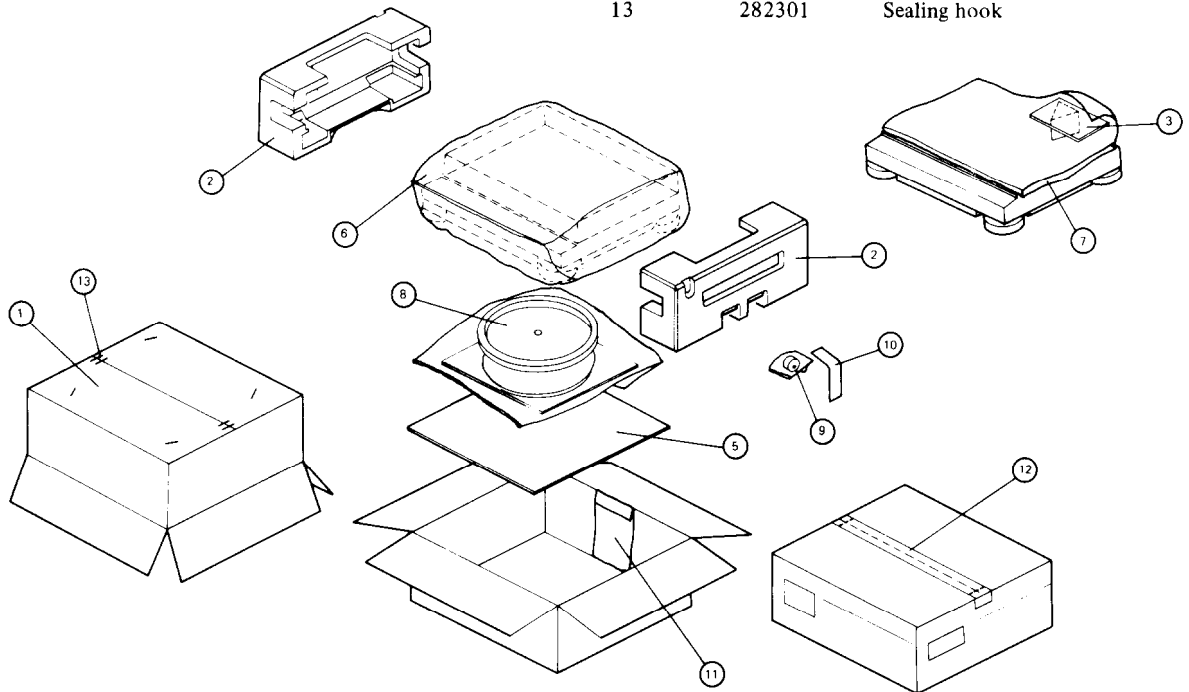

## ONKYO CORPORATION

International Division: No. 24 Mori Bldg., 23-5, 3-chome, Nishi-Shinbashi, Minato-ku, Tokyo, Japan  
 Telex: 2423551 ONKYO J. Phone: 03-432-6981

## ONKYO U.S.A. CORPORATION

200 Williams Drive, Ramsey, N.J. 07446 Tel. 201-825-7950

## ONKYO DENTSCHLAND GMBH, ELECTRONICS

8034 München-Germering, Industriestrasse 18, West Germany. Telex: 521726 Telefon: (089)-84-3071