



Deze download wordt u gratis aangeboden door Pick-upnaalden.nl

Web : [www.pickupnaalden.com](http://www.pickupnaalden.com)  
Email : [info@pick-upnaalden.nl](mailto:info@pick-upnaalden.nl)  
Facebook : [www.facebook.com/pickupnaalden](http://www.facebook.com/pickupnaalden)  
Twitter : [twitter.com/Pickupnaalden](http://twitter.com/Pickupnaalden)  
Google+ : [https://plus.google.com/+FCaris\\_pickupnaalden](https://plus.google.com/+FCaris_pickupnaalden)

*Artistry in Sound*  
**ONKYO**<sup>®</sup>

# ***CP-101A***

**Auto-Return Turntable**

**Instruction Manual**

● Congratulations on your purchase of the ONKYO CP-101A Turntable. ● Please read this manual thoroughly before making connections and turning your new CP-101A on. ● Follow these instructions to obtain optimum performance and maximum listening enjoyment from your new CP-101A. ● Please retain this manual for future reference.

## Precautions

### "WARNING"

"TO REDUCE THE RISK OF FIRE OR ELECTRIC SHOCK, DO NOT EXPOSE THIS APPLIANCE TO RAIN OR MOISTURE."

### "CAUTION"

"TO REDUCE THE RISK OF ELECTRIC SHOCK, DO NOT REMOVE COVER (OR BACK). NO USER-SERVICEABLE PARTS INSIDE. REFER SERVICING TO QUALIFIED SERVICE PERSONNEL."



### "CAUTION"

"TO PREVENT ELECTRIC SHOCK, DO NOT USE THIS (POLARIZED) PLUG WITH AN EXTENSION CORD, RECEPTACLE OR OTHER OUTLET UNLESS THE BLADES CAN BE FULLY INSERTED TO PREVENT BLADE EXPOSURE."

### Warranty card

The serial number is written on the rear panel of this unit. Copy the serial number and model number onto your warranty card and keep it in a safe place.

## Important safeguards

1. **Read Instructions** – All the safety and operating instructions should be read before the appliance is operated.
  2. **Retain Instructions** – The safety and operating instructions should be retained for future reference.
  3. **Heed Warnings** – All warnings on the appliance and in the operating instructions should be adhered to.
  4. **Follow Instructions** – All operating and user instruction should be followed.
  5. **Water and Moisture** – The appliance should not be used near water – for example, near a bathtub, wash-bowl, kitchen sink, laundry tub, in a wet basement, or near a swimming pool, and the like.
  6. **Carts and Stands** – The appliance should be used only with a cart or stand that is recommended by the manufacturer.
- 6A An appliance and cart combination should be moved with care. Quick stops, excessive force, and uneven surfaces may cause the appliance and cart combination to overturn.
- PORTABLE CART WARNING
- 
- S3125A
7. **Wall or Ceiling Mounting** – The appliance should be mounted to a wall or ceiling only as recommended by the manufacturer.
  8. **Ventilation** – The appliance should be situated so that its location or position does not interfere with its proper ventilation. For example, the appliance should not be situated on a bed, sofa, rug, or similar surface that may block the ventilation openings; or, placed in a built-in installation, such as a bookcase or cabinet that may impede the flow of air through the ventilation openings.
  9. **Heat** – The appliance should be situated away from heat sources such as radiators, heat registers, stoves, or other appliances (including amplifiers) that produce heat.



- The lightning flash with arrowhead symbol, within an equilateral triangle, is intended to alert the user to the presence of uninsulated "dangerous voltage" within the product's enclosure that may be of sufficient magnitude to constitute a risk of electric shock to persons.



- The exclamation point within an equilateral triangle is intended to alert the user to the presence of important operating and maintenance (servicing) instructions in the literature accompanying the appliance.

### "ATTENTION"

"POUR PREVENIR LES CHOCS ELECTRIQUES NE PAS UTILISER CETTE FICHE POLARISEE AVEC UN PROLONGATEUR, UNE PRISE DE COURANT OU UNE AUTRE SORTIE DE COURANT, SAUF SI LES LAMES PEUVENT ETRE INSEREES A FOND SANS EN LAISSER AUCUNE PARTIE A DECOUVERT."

### Cabinet Composition

Turntable Board:	Plastic
Bottom Board:	Plastic
Dust Cover:	Polystyrene

10. **Power Sources** – The appliance should be connected to a power supply only of the type described in the operating instructions or as marked on the appliance.
11. **Polarization** – If the appliance is provided a polarized plug having one blade wider than the other, please read the following information; The polarization of the plug is a safety feature. The polarized plug will only fit the outlet one way. If the plug does not fit fully into the outlet, try reversing it. If there is still trouble, the user should seek the services of a qualified electrician. Under no circumstances should the user attempt to defeat the polarization of the plug.
12. **Power-Cord Protection** – Power-supply cords should be routed so that they are not likely to be walked on or pinched by items placed upon or against them, paying particular attention to cords at plugs, convenience receptacles, and the point where they exit from the appliance.
13. **Cleaning** – The appliance should be cleaned only as recommended by the manufacturer.
14. **Nonuse Periods** – The power cord of the appliance should be unplugged from the outlet when left unused for a long period of time.
15. **Object and Liquid Entry** – Care should be taken so that objects do not fall and liquids are not spilled into the enclosure through openings.
16. **Damage Requiring Service** – The appliance should be serviced by qualified service personnel when:
  - A. The power-supply cord or the plug has been damaged; or
  - B. Objects have fallen, or liquid has been spilled into the appliance; or
  - C. The appliance has been exposed to rain; or
  - D. The appliance does not appear to operate normally or exhibits a marked change in performance; or
  - E. The appliance has been dropped or the enclosure damaged.
17. **Servicing** – The user should not attempt to service the appliance beyond that described in the operating instructions. All other servicing should be referred to qualified service personnel.

## Turntable assembly

- Remove all packing materials and wipe the unit clean.
- For safety, do not connect the power cord or any other wires until assembly and tonearm adjustment have been completed.
- Remove the turntable platter, rubber mat, and accessories which are packed separately.
- save the packing materials for use if you ship the unit again.

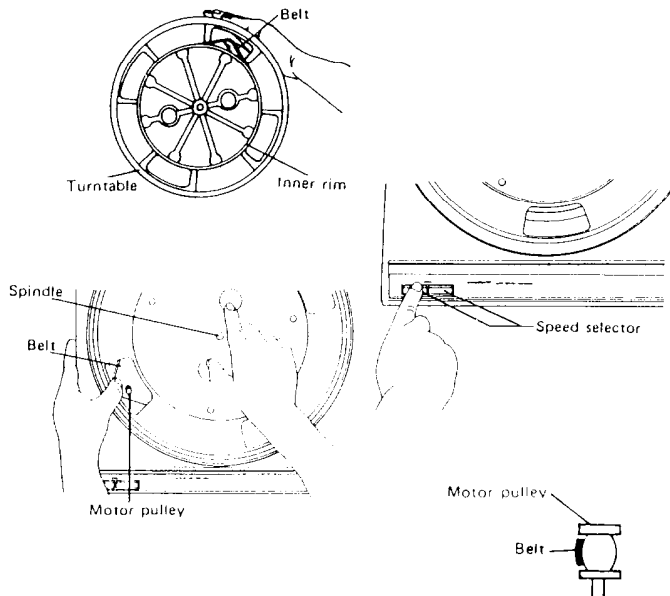

### Mounting the Platter

1. Set the speed selector to 33 rpm.
2. Place the drive belt around the lower inner rim of the turntable platter. Use your finger to pull the end of the belt through the turntable platter hole as shown. Be sure the belt is not twisted and make sure the belt makes contact with the lower portion of the inner rim.
3. Place the turntable platter on the spindle, keeping the belt in place.
4. Place the end of the drive belt around the motor pulley as shown.
5. The belt should lie flat on the pulley.
6. Rotate the turntable a couple of times to see that the drive belt is properly mounted.
7. Lay the rubber mat on top of the turntable platter.

### Adjusting the Tonearm

1. Remove the hook, stylus cover, and vinyl ribbon holding the tonearm. The tonearm, cartridge, and stylus assembly are extremely delicate pieces of equipment, handle them with care.
2. Place the counterweight on the rear end of the tonearm and screw it on until the tonearm is evenly balanced. (The cueing lever must be in the "DONW" position.)
3. Align the zero line of the tracking force indicator ring with the index line.
4. Rotate the counterweight until the indicator reads "2". This provides the correct tracing force of 2 grams for the cartridge being used. If a cartridge other than that provided is to be used, the tracking force must be adjusted for that cartridge as specified by the cartridge manufacturer.
5. Adjust the anti-skating control dial to the same value as the tracking force ("2" in this case).

### Turntable Placement

Because a turntable is a precision instrument, it is very sensitive to vibrations, temperature, humidity, dust, and external noises. To receive optimum performance, be sure to avoid:

- 1) Vibrations and unevenness.
- 2) Direct exposure to sunlight, heaters, or any other sources of heat
- 3) Placing the turntable near the speakers (howling may result)
- 4) Magnetic fields.

### Replacing the Stylus (ONKYO DN-74ST)

Under normal use, the diamond stylus provided with this turntable will last about 500 hours (1000 LP record sides). Timely replacement is essential because a worn stylus will not only adversely affect music quality but also damage the record itself. To replace the stylus, gently remove the plastic section under the cartridge by hand and replace it with a new one. The stylus is extremely delicate and must never come into contact with your fingers or any hard object.

## Turntable controls

### 1 Speed Selector

The turntable can be set to operate at either the 33 rpm or 45 rpm position.

### 2 Reject Button

To stop the record before it has ended, press the "REJECT" button. The tonearm will automatically rise and return to the arm rest and the turntable will stop.

### 3 Cueing Lever

When operating the turntable, the cueing lever is used to raise and lower the tonearm. It is also used when selecting specific bands to be played on an LP record.

### 4 Tonearm

A straight statically balanced tonearm is employed in this unit.

### 5 Headshell

The headshell can be removed from the tonearm if necessary by rotating the headshell connection screw counterclockwise.

### 6 Headshell Connection Screw

The headshell connection screw holds the headshell (with cartridge and stylus assembly) in place on the tonearm.

### 7 Arm Rest

The tonearm should rest on the arm rest when not in use. A hook is provided to prevent accidentally knocking the tonearm off the arm rest.

#### 8 Counterweight

The counterweight must be adjusted to provide the proper tracking force for the cartridge being used.

#### 9 Anti-skating Control

The anti-skating control is set to the same value as the tracking force.

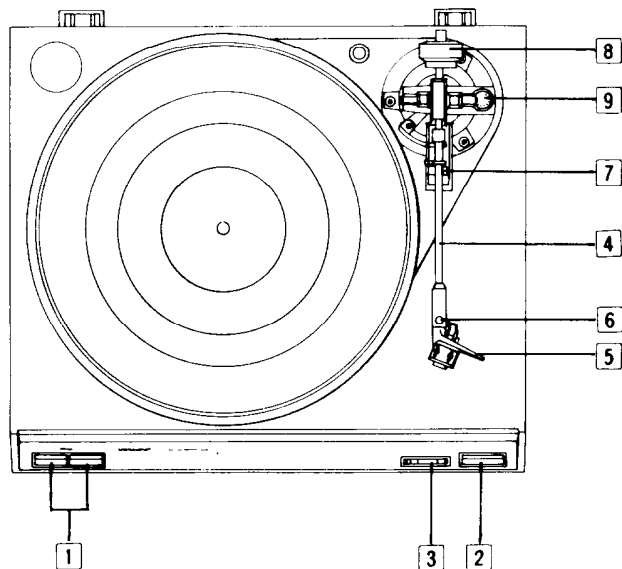

## Playing a record

Before playing records, be sure that the speakers and turntable are properly connected to the integrated amplifier and that the tracking force is set to the correct value for the cartridge in use.

Verify that the left (white) and right (red) output connectors are not reversed.

1. Place a record on the turntable.
2. Lift the cueing lever to its "UP" position.
3. Manually place the tonearm over the record. The turntable will automatically begin to rotate.
4. Select the proper turntable speed.
5. Put the stylus directly over the desired section of the record and return the cueing lever to the "DOWN" position. The stylus will slowly lower to the record surface and record play will begin.
6. At the end of the record, the tonearm will automatically return to the arm rest and the turntable will stop.
7. To stop the turntable before the end of a record, lift the cueing lever to its "UP" position to raise the stylus off the record surface. Next, return the tonearm to the arm rest manually. This can also be accomplished by simply pressing the reject button. The tonearm will automatically return to the arm rest after which the turntable will stop.
8. To protect your cartridge, always be sure to secure the tonearm with the tonearm hook after use.

**Caution:** Never touch the tonearm during automatic operation.

## Specifications

Type:	2-speed automatic-return turntable with cueing lever
Turntable Platter:	31 cm (12-1/4") Aluminum diecast
Motor:	DC servo motor
Speeds:	33-1/3 rpm, 45 rpm
Wow & Flutter:	0.045% WRMS
Signal-to-Noise Ratio:	66 dB (IEC-Y, DIN-B)
Tonearm:	Static balanced straight-type pipe arm
Effective Arm Length:	210mm (8-5/16")
Overhang:	13mm (1/2")
Maximum Tracking Error:	+4.5 degrees, -1 degree
Cartridge:	
Type:	Moving magnet OC-74M
Frequency Response:	20Hz - 20,000Hz
Recommended Load Impedance:	47 kohms
Recommended Tracking Force:	2 grams
Output Voltage:	2.5mV
Replacement Stylus:	DN-74ST
Power Supply Rating:	AC120V, 50/60Hz
Dimensions (W×H×D):	418mm×132mm×374mm 16-1/2"×5-1/6"×14-3/4"
Weight:	3,7kg (8,2lbs.)

Optional Recommended Headshell: SH-21F

In the interest of further product improvements, specifications are subject to change without notice.

## ONKYO CORPORATION

International Division: Onarimon Yusen Bldg., 23-5, Nishi-Shimbashi 3-chome, Minato-ku, TOKYO 105, JAPAN Tel: 03-3432-6978 Fax: 03-3436-6979  
ONKYO U.S.A. CORPORATION  
200 Williams Drive, Ramsey, N.J. 07446, U.S.A. Tel: 201-825-7950 Fax: 201-825-8150

