



Deze download wordt u gratis aangeboden door Pick-upnaalden.nl

Web : www.pickupnaalden.com
Email : info@pick-upnaalden.nl
Facebook : www.facebook.com/pickupnaalden
Twitter : twitter.com/Pickupnaalden
Google+ : https://plus.google.com/+FCaris_pickupnaalden

ONKYO® SERVICE MANUAL

FULLY AUTOMATIC TURNTABLE MODEL CP-1011F



D model

TABLE OF CONTENTS

Item	Page
Specifications	2
Attaching the cartridge	2
Exploded view	3
Adjustment procedures	7
Printed circuit board view	8
Schematic diagram	9
Packing procedures	10

ONKYO®
AUDIO COMPONENTS

SPECIFICATIONS

Type:	2-speed fully automatic turntable
Turntable Platter:	30 cm (12") aluminum diecast
Motor:	Electronic servo DC motor, belt drive
Speeds:	33-1/3 rpm, 45 rpm
Speed Controls:	Adjustable range $\pm 3\%$
Wow & Flutter:	0.05% (WRMS)
Signal-to-Noise Ratio:	67 dB (DIN B)
Tonearm:	Lightweight straight-line static balanced pipe tonearm with detachable headshell (ADC type connector) and counterweight with direct tracking force read out.
Suitable Cartridge	
Weight:	5 – 9 grams
Adjustable Range:	3 grams
Maximum Length:	270 mm (10-5/8")
Effective Arm Length:	213 mm (8-3/8")
Overhang:	14 mm (9/16")
Maximum Tracking Error:	+3 degrees, -1.5 degrees (offset angle 21 degrees)

Cartridge (G/W model)

Type:	Moving magnet type (OC – 51M)
Frequency Response:	20 Hz ~ 20,000 Hz
Recommended Load	
Impedance:	47 kohms
Recommended Tracking	
Force:	2 grams
Compliance:	8×10^{-6} cm/dyne
Output Voltage:	3.5 mV
Stylus Tip:	0.5 mil diamond
Replacement Stylus:	DN-51ST
Power Supply:	AC110-120, 220-240V, 50/60Hz (W model) AC120V, 60Hz (D model) AC 220V, 50Hz (G model)
Power Consumption:	3 Watts
Dimensions:	418(W) x 371(D) x 140(H) mm (16-1/2" x 14-1/2" x 5-1/2")
Weight:	4.5kg (9.9 lbs.)

Optional Recommended Headshell SH-21E

In the interest of further product improvements, specifications are subject to change without notice.

ATTACHING THE CARTRIDGE

Attach the cartridge as shown below, connecting each of the color coded lead wires to the proper terminal. If a mistake is made, no sound will be heard or stereo reproduction will be lost. Also, to prevent damage to the stylus during installation operations, leave its cover on or remove the stylus completely.

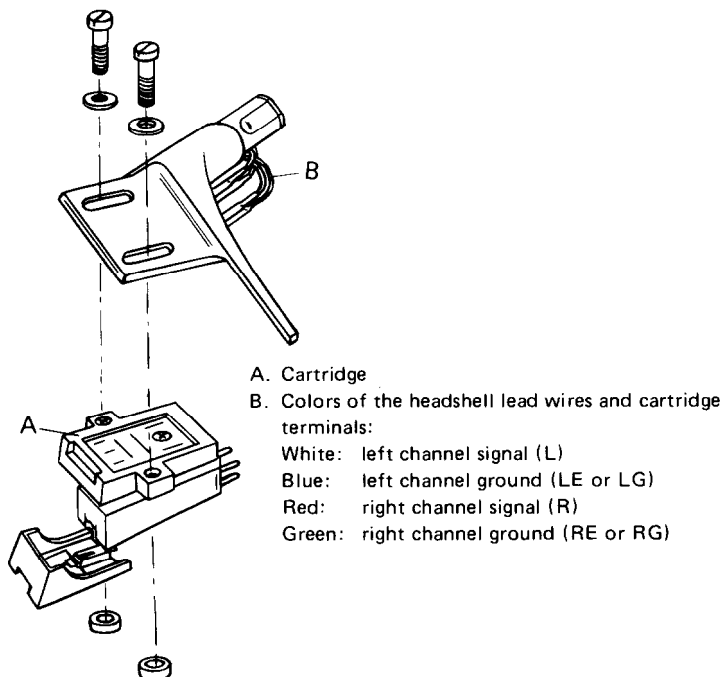

Adjust so the distance between the stylus tip and the base of the headshell is 30 mm (1 3/16") and tighten the screws. This assures the effective length and overhang of the tonearm are correct.

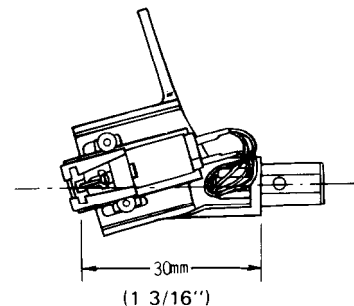

Use the included overhang gauge as shown below, placing the cartridge in the gauge and setting the location of the stylus tip as indicated.

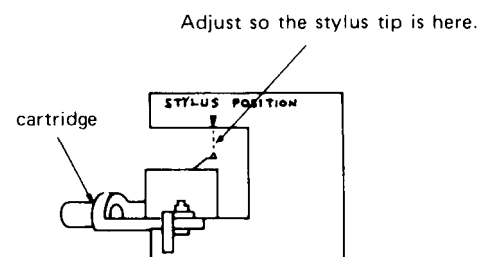

EXPLODED VIEW

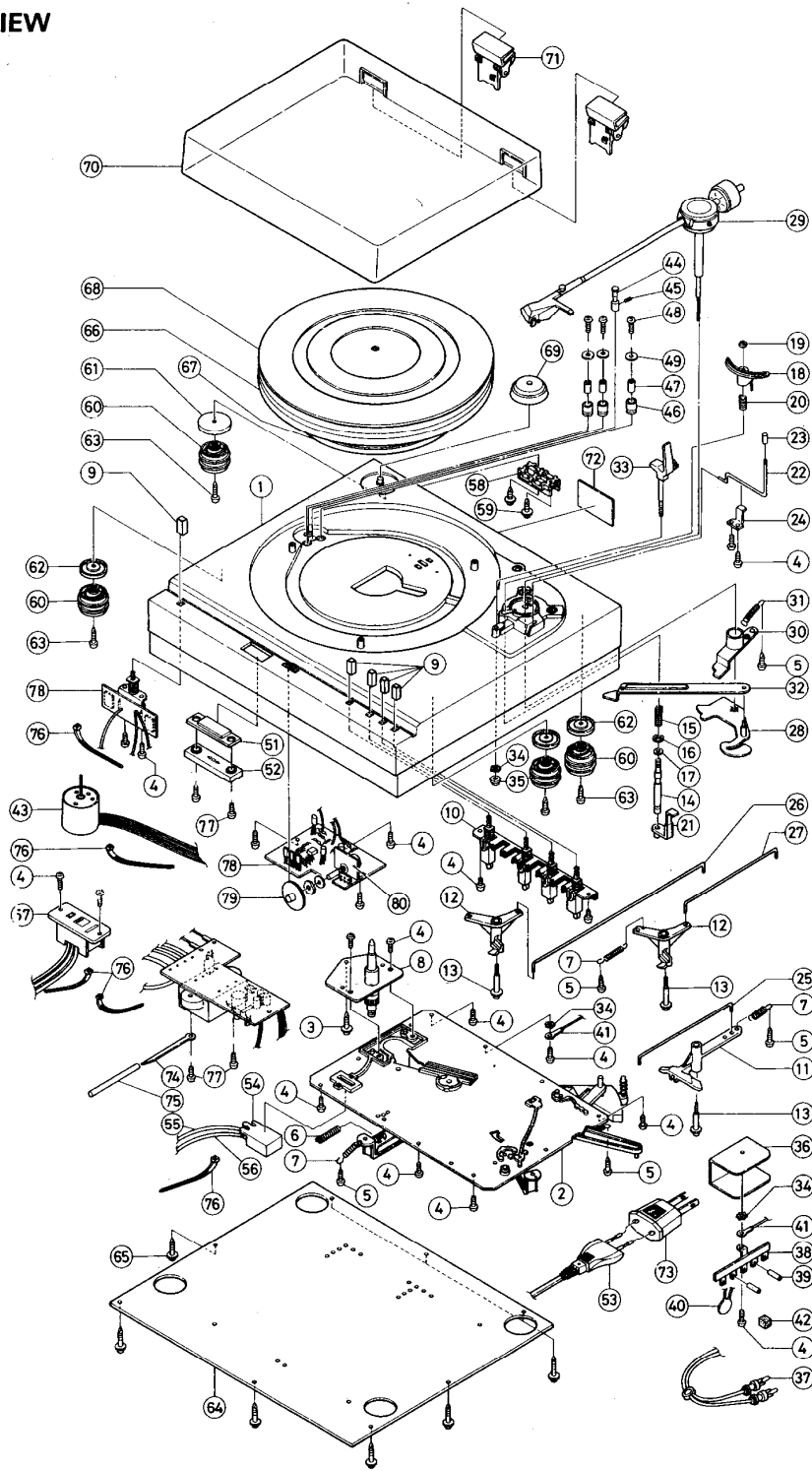

REF. NO.	PARTS NO.	DESCRIPTION	REF. NO.	PARTS NO.	DESCRIPTION	REF. NO.	PARTS NO.	DESCRIPTION
1	24509226	Cabinet ass'y	29	24501321	Screw, tonearm	58	24506517	Holder
2	24506475	Mechanism chassis		24501346	OC-51M, Cartridge (G/W)	59	831130122	TPT+3x12, Screw
3	831130082	TPT+3x8, Screw		24501308	DN-51ST, Stylus (G/W)	60	24509144	Leg
4	838130082	BT+3x8, Screw	30	24506510	Selector	61	24509196	Plate, leg
5	834130122	FMT+3x12, Screw	31	24500771	Spring, start lever	62	24509227	Plate, leg
6	24506519	Spring	32	24506511	Actuating slide	63	833140162	FMT+4x16, Screw
7	24503053	Spring, start lever	33	24506516	Arm rest	64	24509219	Bottom board
8	24506496	T.T. shaft ass'y	34	87313008	TOW-3, Toothed washer	65	831140125	4STW+12B, Tapping screw
9	28320303	Button	35	86213010	M3, Nut	66	24502117	Turntable platter
10	24503105	Push switch	36	24506032	Shielded plate	67	242129B	Belt
11	24506498	Start cam	37	24505126	Output cable	68	24509111B	Motor, volume
12	24506499	Cam	38	24506034	Terminal	69	242049A	45 rpm adaptor
13	24506523	Special screw	39	24505012	Tube	70	24509215	Dust cover
14	24506503	Shaft, elevation	40	24505143	0.005µF, 50V, Ceramic capacitor	71	28180062	Hinge
15	24504279	Spring, elevation	41	24509104	Cable	72		Rating label
16	893030	E-3, Circlip	42	24509104	Mounting stud	73		Conversion plug (W)
17	24506506	4.7φ x 8φ x 0.5t, Nylon washer	43	24502116	Motor with pulley	74	251073	Terminal
18	24506504	Plate, elevation	44	24502115	Pulley	75		Tube
19	24506275	Nut	45	801161	T-2x3, Screw, pulley	76		Binder
20	24503075	Spring, cam	46	24502060	Cushion, motor	77		P.c.b. ass'y
21	24506505	Lifter arm	47	24506190	Pipe	78		L.E.D. and motor control p.c.b.
22	24506507	Cue lever	48	82112612	FM+2.6x12, Screw		24505132	Speed selector switch p.c.b.
23	24506399	Knob, lifter lever	49	87613013	FW3x13x0.8t, Washer		24505138	Power supply p.c.b. (D)
24	24506508	Pressure plate, lever	51	24504308	Cover, L.E.D.		24505142	Power supply p.c.b. (G)
25	24506513	Rod, selector	52	24504307	Guide, L.E.D.		24505139	Power supply p.c.b. (W)
26	24506514	Rod, selector	53	24505076	Power supply cable (D)	79	24506512	Knob, volume
27	24506515	Rod, selector		24505068	Power supply cable (G/W)	80	24506521	Bracket, volume
28	24506509	Tonearm base	54	24503023	Micro switch			D: Only 120V model
29	24501349	Tonearm ass'y	55		Cable			G: Only 220V model
	24501350	Counter weigh.	56		Cable			W: Only 110/120, 220/240V model
	24501354	Headshell	57		Voltage selector (W)			

MECHANISM-EXPLODED VIEW

CP-1011F

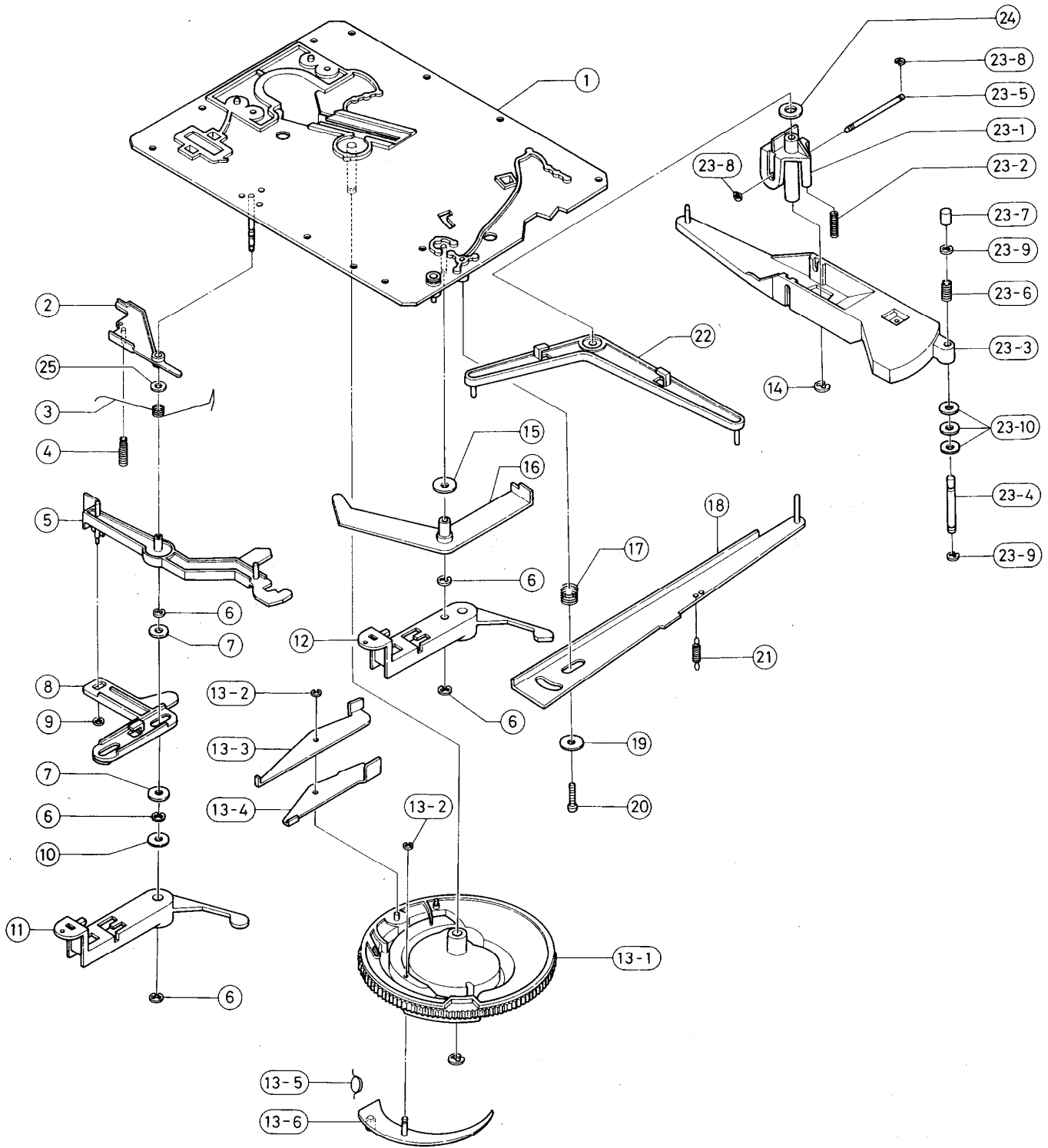

- 6 -

- 5 -

REF. NO.	PARTS NO.	DESCRIPTION	REF. NO.	PARTS NO.	DESCRIPTION	REF. NO.	PARTS NO.	DESCRIPTION
1		Sub-chassis ass'y	13-2	893020	E-2, Circlip	23	24506489	Rotation plate ass'y
2	24506477	Clutch lever	13-3	24506099	Clutch plate	23-1		Base
3	24506478	Spring, clutch lever	13-4	24500405	Guide, clutch plate	23-2	24506491	Spring
4	24503029	Spring, clutch lever	13-5	24501012	Spring	23-3	24506492	Rotation plate
5	24503079	Switch lever (2)	13-6	24500338	Lever	23-4	24506493	Shaft, friction
6	893030	E-3, Circlip	14	893040	E-4, Circlip	23-5	24501019	Shaft, plate
7	24506480	FW4.7φx1.2φx0.5 ^t , Washer	15	24506485	FW4.7φx1.2φx0.8 ^t , Washer	23-6	24506494	Spring, friction
8	24506518	Repeat lever	16	24500408	Guide, selector	23-7	24500516	Friction rubber
9	24506482	CSTW-2.4, CS ring	17	24506486	Spring	23-8	893020	E-2, Circlip
10	24506483	FW4.7φx1.2φx0.3 ^t , Washer	18	24500301	Arm, selector	23-9	893030	E-3, Circlip
11	24506484	Start lever	19	24506487	FW3.2φx1.3φx0.8 ^t , Washer	23-10	24506495	4.7φx1.0φx0.5 ^t , Fiber washer
12	24506481	Repeat lever	20	833130162	FMT3x16, Screw	24	24506501	FW6.2φx1.2φx0.3 ^t , Washer
13	24500747	Main gear ass'y	21	24503054	Spring, selector arm	25	24506502	FW6.2φx1.2φx0.2 ^t , Washer
13-1		Main gear	22	24506488	Lever, switch			

ADJUSTMENT PROCEDURES

1. Auto-return position

Adjust the return position by the eccentric pin attached by the tonearm base. To adjust the return position for faster, turn the eccentric pin clockwise. To adjust the return position for later, turn the eccentric pin counter-clockwise.

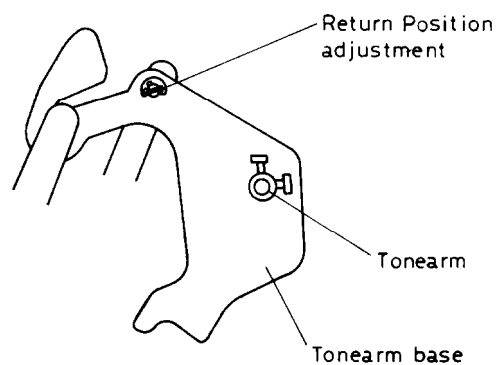

2. Tonearm height

- 1) Press the record size selector to 17cm position and the power switch to the ON position.
 - 2) Press the play button.
 - 3) As soon as the tonearm comes over the turntable platter, press the power switch to the off position.
 - 4) Adjust the screw on the lifter plate for 12 ± 1 mm height between the stylus tip and the turntable platter mat.
- Note: To adjust the height for lower, turn the screw clockwise. To adjust the height for higher, turn the screw counter-clockwise.

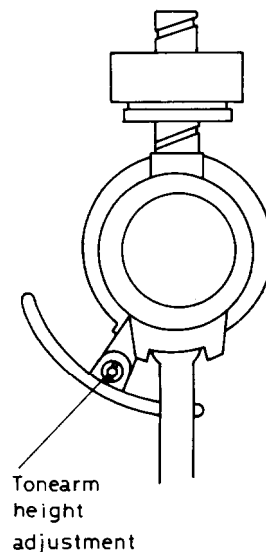

3. Lead-in position

Remove the rubber cap. Press the record size selector to 30cm position and the speed selector to 45 r.p.m. To adjust lead-in position for faster (outside), turn the eccentric pin clockwise. To adjust the lead-in position for later (inside), turn the eccentric pin counter-clockwise.

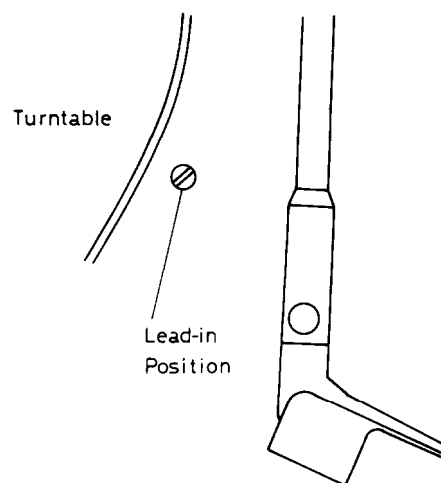

4. Speed control

- 1) Put the stroboscope on the turntable platter.
- 2) Set the speed control so that the center L.E.D. lights up.
- 3) Press the speed selector switch to 33 r.p.m., and adjust VR201 so that the stroboscope stripes appear to be stationary.
- 4) Then switch over to 45 r.p.m., and adjust VR202 to obtain the same stationary stroboscope condition.

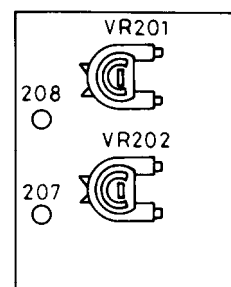

PRINTED CIRCUIT BOARD VIEW FROM BOTTOM SIDE

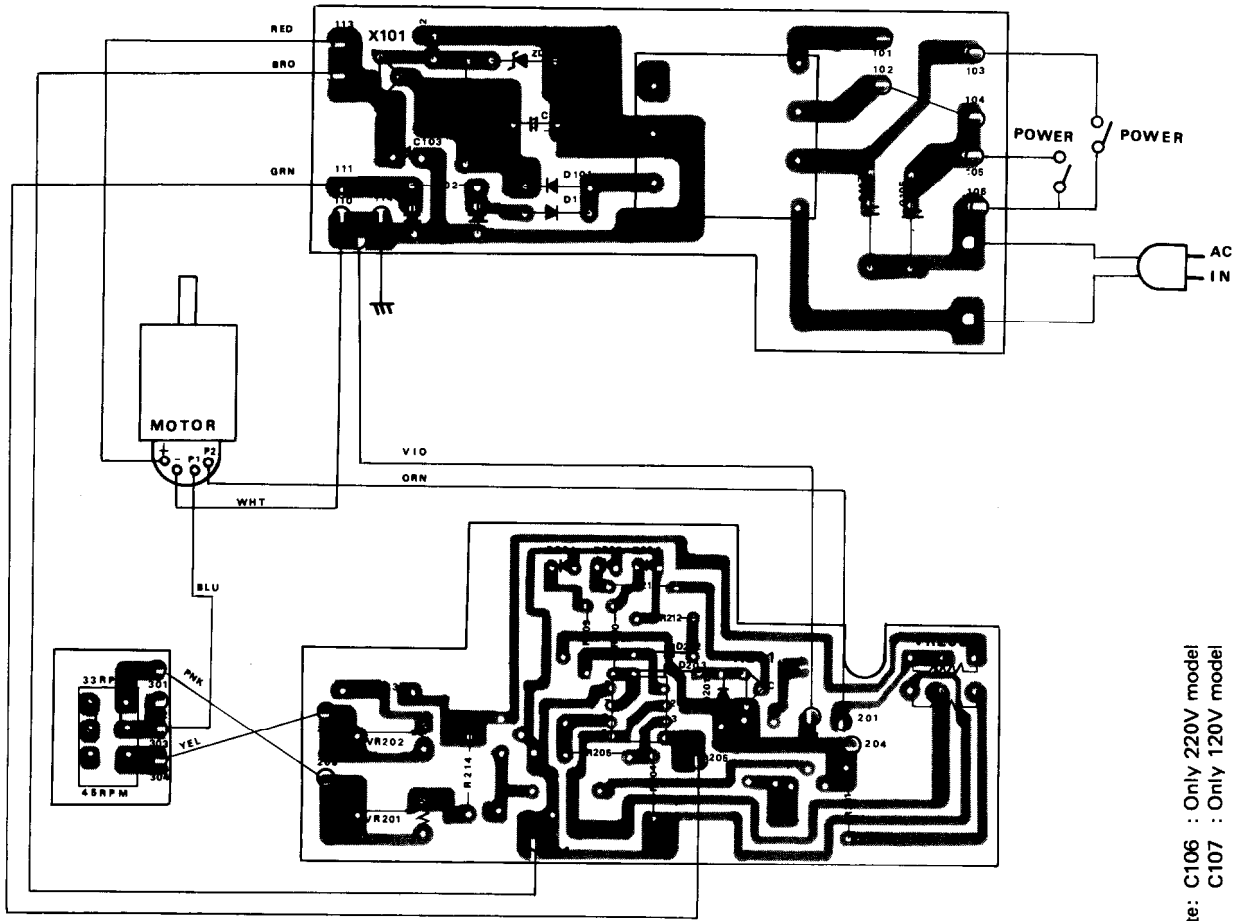

POWER SUPPLY PC BOARD

CIRCUIT NO.	PARTS NO.	DESCRIPTION
X101	Transistor	2SD468(B) or 2SD468(C)
	2211682 or 2211683	
ZD101	Diodes	RD12EB1 W03(B) 1S953
	D101	
	D102	
R101	Resistor	441622714 270Ω, 1W, Metal oxide film
	441622714	
C101	Capacitors	470μF, 16V, Elect. 47μF, 16V, Elect. 0.047μF, 250V, IS (G/W model) 0.01μF, 125V, CS (D model)
	C102-C105	
	C106	
	C107	
PT101	Power transformer	NPT-720D, D model 230448 NPT-720G, G/W model 230449
	A101	
A101	Power supply cable	24505076 D model 24505068 G/W model

INDICATOR AND MOTOR DRIVE CIRCUIT PC BOARD

CIRCUIT NO.	PARTS NO.	DESCRIPTION
IC201	IC	NJM4558D
	222465	
X201	Transistor	2SC945(P) or 2SC945(Q)
	2210353 or 2210354	
D201-D203	Diodes	1S953 SEL-1121R(B) or SEL-1121R(C)
	D204, D206	
	D205	
VR201	Resistors	VZ083L1 5K, Semi-fixed VZ083L1 10K, Semi-fixed N16RG2KB15, Speed control variable
	VR202	
	VR203	

SPEED SELECTOR PC BOARD

CIRCUIT NO.	PARTS NO.	DESCRIPTION
SW301	25035189	Speed selector

Note: C106 : Only 220V model
C107 : Only 120V model

SCHEMATIC DIAGRAM

- X101 2SD667(B)(C) 2SD571(L)(M)
2SD468(B)(C) 2SD778(B)(C)
2SD471(M)(L) or 2SC2236(O)(Y)
- X201 2SC945(P)(Q) or 2SC1815(Y)(GR)
- IC201 JPC4558C
NJM4558D
NJM4559D
RC4558P or TL4558P

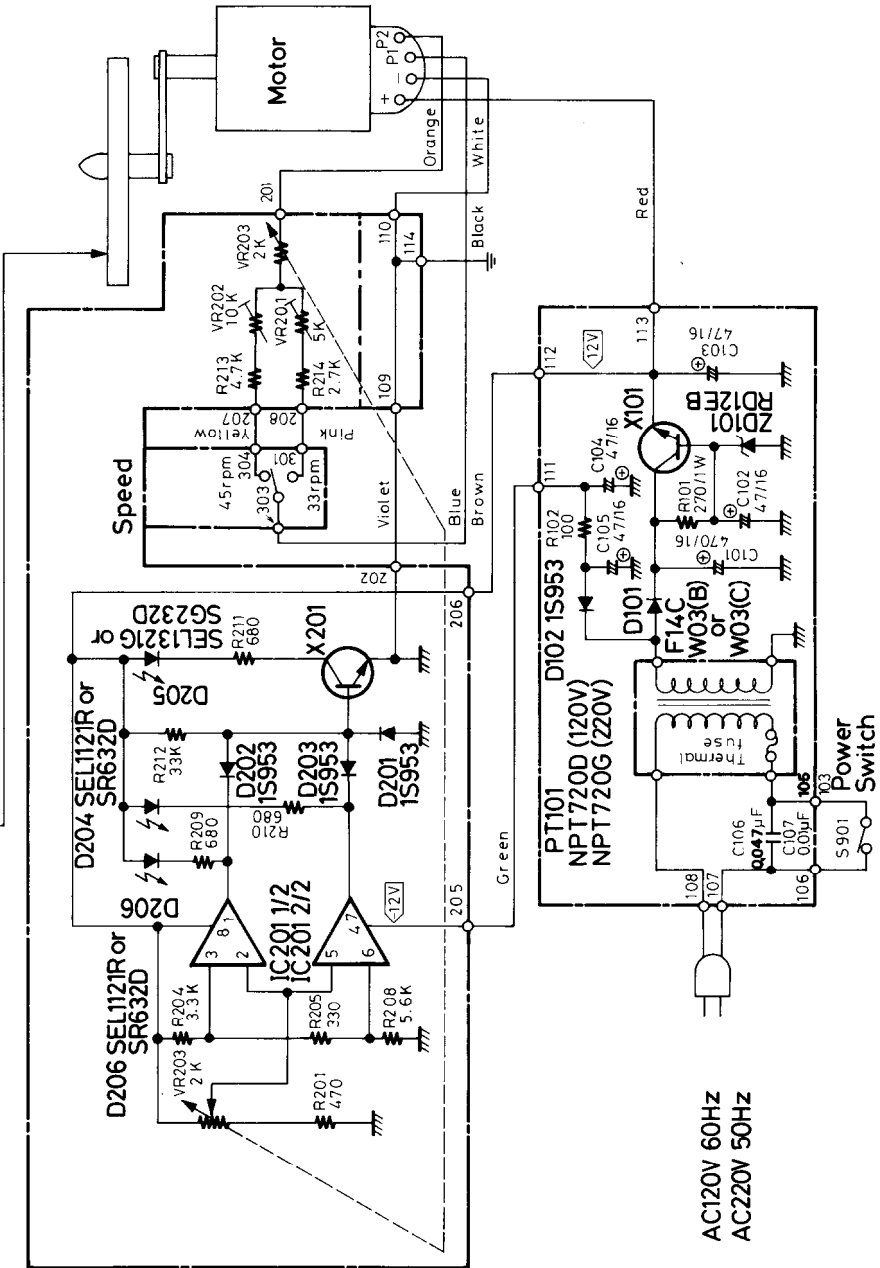
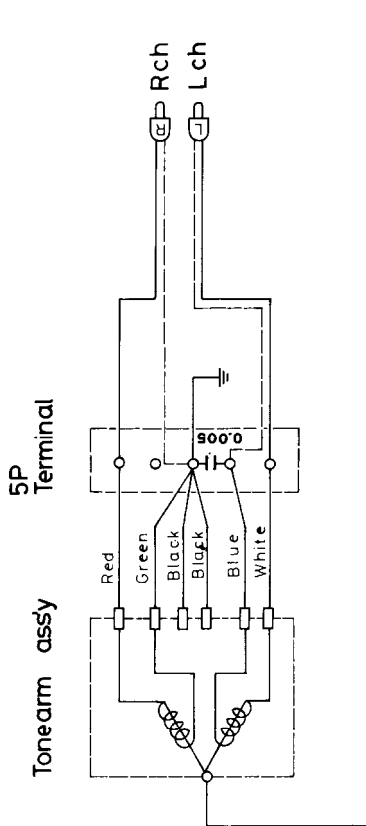

- NOTE:
1. ALL RESISTORS ARE IN OHMS, 1/4WATT UNLESS OTHERWISE NOTED.
 2. ALL CAPACITORS ARE IN μ F, 50MV UNLESS OTHERWISE NOTED.
 3. ELECTROLYTIC CAPACITORS ($\frac{\square}{\square}$) ARE IN μ F/MV.
 4. VOLTAGE IS MEASURED WITH V.T.V.M. WHEN TONEARM IS IN REST POSITION.
 5. CIRCUIT IS SUBJECT TO CHANGE FOR IMPROVEMENT.
 6. C106 : Only 220V model
C107 : Only 120V model

ONKYO CORPORATION

PACKING PROCEDURES

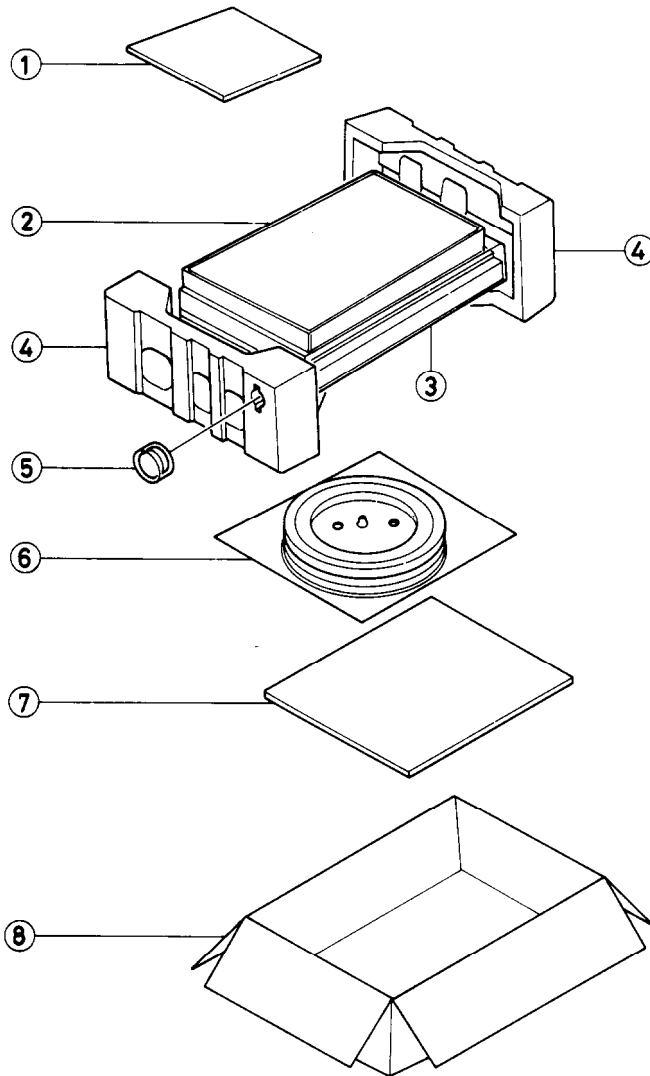

D Model

REF. NO.	PARTS NO.	DESCRIPTION
1	292049A	Accessory bag ass'y
	24509197	45 r.p.m. adaptor
	24501330	Overhang gauge
	29340459	Cartridge mounting part ass'y
	29365006	Instruction manual
	29358002	Warranty card (Only U.S.A. model)
		Service station list (Only U.S.A. model)
2	29100005	220x330mm, Poly bag
3	29100050	Protection sheet
4	29095012	Protection sheet
5	24509223	Pad
6	24501350	Counter weight
	29100002	30x150mm, Poly bag
	24502117	Turntable platter
	242129B	Belt
	24509111B	T.T. mat
	29100046	370x470mm, Poly bag
7	24509224	Pad sheet
8	29050394	Master carton box

G/W Model

REF. NO.	PARTS NO.	DESCRIPTION
1	292049A	Accessory bag ass'y
	29340460	45 r.p.m. adaptor
	29365005-2	Instruction manual
		Warranty card (Only Germany model)
2	29100005	220x330mm, Poly bag
3	29100050	Protection sheet
4	29095012	Protection sheet
5	24509223	Pad
6	24501350	Counter weight
	29100002	30x150mm, Poly bag
	24502117	Turntable platter
	242129B	Belt
	24509111B	T.T. mat
	29100046	370x470mm, Poly bag
7	24509224	Pad sheet
8	27050394	Master carton box

Notes: D --- 120V model G --- 220V model W --- 110 ~ 120/220 ~ 240V model

ONKYO CORPORATION

International Division : No. 24 Mori Bldg., 23-5, 3-chome, Nishi-Shinbashi, Minato-ku, Tokyo, Japan
 Telex : 2423551 ONKYO J. Phone : 03-432-6981

ONKYO U.S.A. CORPORATION

Eastern Office

42-07 20th Avenue, Long Island City, New York 11105, U.S.A. Phone : (212) 728-4639

Midwest Office

935 Sivert Drive, Wooddale, Illinois 60191, U.S.A. Phone : (312) 595-2970

C/O Demark Industries Inc.

20620 Nordhoff Chatsworth, Cal. 91311, U.S.A. Phone : (213) 998-6501

ONKYO DEUTSCHLAND GMBH, ELECTRONICS

8034 München-Germering, Industriestrasse 18, West Germany. Telex : 521726 Telefon : (089)-845-5041